



SymplyPRO XTL 8 Tape Autoloader User Guide

Thank you for purchasing SymplyPRO XTL 8 Tape Autoloader

If you have any support questions that are not addressed in this document, then please check our extensive FAQs or submit a support ticket on our support site.

Your feedback is important to us, so please let us know what you think of our products via email hello@gosymply.com



SYMPPLY provides this publication “as is” without warranty of any kind, either express or implied, including but not limited to the implied warranties of merchantability or fitness for a particular purpose. SYMPPLY may revise this publication from time to time without notice.

IN NO EVENT WILL SYMPPLY. BE LIABLE FOR DIRECT, INDIRECT, SPECIAL, INCIDENTAL, SPECULATIVE OR CONSEQUENTIAL DAMAGES ARISING FROM THE USE OR INABILITY TO USE THIS PRODUCT OR DOCUMENTATION EVEN IF ADVISED OF THE POSSIBILITY OF SUCH DAMAGES. IN PARTICULAR, SYMPPLY. SHALL NOT HAVE LIABILITY FOR ANY HARDWARE, SOFTWARE, OR DATA STORED OR USED WITH THE PRODUCT, INCLUDING THE COSTS OF REPAIRING, REPLACING, INTEGRATING, INSTALLING, OR RECOVERING SUCH HARDWARE, SOFTWARE, OR DATA

Table of Contents

Regulatory Information.....	6
FCC (United States)	7
Perchlorate warning.....	7
Canadian Verification	7
CE Statement.....	7
VCCI	8
Recycling and disposal.....	8
Warnings and Symbols.....	9
Document Revision.....	10
About this guide.....	10
COPYRIGHT STATEMENT	10
Introduction.....	11
Preparing the host.....	11
SymplyPRO XTL 8 Hardware Overview	12
SymplyPRO XTL 8 Part Numbers.....	12
Physical Specifications SymplyPRO XTL 8	12
Environmental Specifications SymplyPRO XTL 8	13
Transport and Storage of Library and Data Cartridge	13
SymplyPRO XTL 8 Front View	14
SymplyPRO XTL 8 Operator Control Panel (OCP).....	14
SymplyPRO XTL 8 OCP LEDs Guide.....	15
SymplyPRO XTL 8 Push Button Guide	16
SymplyPRO XTL 8 Rear View	17
SymplyPRO XTL 8 Internal View	18
Acclimatization Time for Autoloader and Data Cartridge.....	19
LTO Drive and Data Cartridge Compatibility Guide.....	20
LTO-9 Media Optimization.....	20
Installing the SymplyPRO XTL 8	21
Unpacking the SymplyPRO XTL 8.....	21
What's in the box?	22
Location Requirements	23
SAS Configuration Requirements	24
Fibre Channel Configuration Requirements	25
Removing the shipping lock	26
Rack mounting the autoloader.....	27

To install the autoloader in a rack:	27
User operation of the SymplyPRO XTL 8.....	30
Default Username, Password and IP Configuration	30
Remote Management Unit (Web Interface) Credentials	30
Default IP Address	30
Operator Control Panel (OCP) Credentials	30
Before power on the SymplyPRO XTL	30
Connecting Data Ports on the Tape Drive Modules	32
Connecting Data Ports on SAS Drive module	32
Connecting Data Ports on FC Drive module.....	32
Power On/Off the SymplyPRO XTL.....	33
Power-On Display	33
Power on LED Sequence.....	34
Different Operating Modes of the SymplyPRO XTL 8.....	35
Operator Control Panel (OCP) Philosophy	35
OCP Input Modes	36
Selectable predefined values	36
Toggle values	36
Numerical values.....	36
Flow Chart for the OCP Menu	37
OCP Status Information.....	37
OCP Status Information (Continued...)	38
OCP Status Information (Continued...)	39
OCP Status Information (Continued...)	40
OCP Status Information (Continued...)	41
OCP Inventory.....	42
OCP Commands.....	43
OCP Configuration.....	44
OCP Configuration (Continued...)	45
OCP LTO Drive Configuration Menu	46
OCP Autoloader Service Menu	47
OCP Autoloader Service Menu	48
OCP LTO Drive Service Menu.....	49
OCP LTO Drive Firmware Upgrade Menu	50
Tape Cartridges and Magazines.....	51
Using and Maintaining Tape Cartridges.....	51

Labeling Tape Cartridges	51
Write Protecting Tape Cartridges.....	53
Read and Write Compatibility.....	53
Barcode Reader.....	54
Magazines	54
Inserting tape cartridges into a magazine	54
Removing and replacing a magazine using the OCP	55
To remove a magazine using the OCP:.....	55
Removing and replacing a magazine using the RMU.....	55
Slot numbering – Left Magazine	56
Slot numbering – Right Magazine	56
Mailslot	57
Remote management unit (RMU).....	58
RMU Autoloader Status Icons.....	59
RMU Login	59
RMU Autoloader Information	60
Viewing Autoloader Information	60
Viewing static drive information	61
RMU Autoloader Status	61
View Drive Information	62
Viewing the tape cartridge inventory	62
Using RMU To Configure the XTL 8	62
Changing the system configuration.....	62
Changing the drive configuration.....	63
Changing the network configuration	63
Changing the usernames and password.....	64
Setting date/time	64
Setting error log mode	64
Setting event notification parameters	65
Restoring factory defaults	65
RMU Operations	65
Moving media within the autoloader	65
Determining current media inventory	66
Releasing and replacing magazines	66
Media Initialization.....	66
RMU Servicing	66

Performing general autoloader diagnostics.....	67
Determining and updating firmware	67
Rebooting the autoloader	67
Viewing autoloader logs	68
Cleaning tape drive(s).....	68
Cartridge Memory	68
Hardware servicing of the SymplyPRO XTL 8 autoloader.....	69
Tools that might be needed for servicing.	69
Removing and replacing a tape drive.	70
Removing and replacing the power supply.	71
Removing the power supply.	71
Replacing the power supply	72
Removing and replacing the autoloader controller.....	72
To remove the autoloader controller	72
Replacing the autoloader controller.....	73
Removing and replacing the base chassis	73
Packaging the SymplyPRO XTL before transportation	74
Troubleshooting.....	76
Installation problems	76
Troubleshooting Table	77
Power Problems	77
Tape Movement Problems	77
Media Problems	78
Cleaning	79
OCP Errors (Front Panel)	79
Poor Performance.....	79
Media Attention LED	80
Service Procedures	81
Removing stuck tapes from slots	81
Removing and replacing a magazine using the OCP.....	81
Removing a magazine using Remote Management Interface.....	82
Magazine emergency release	82
Tape autoloader error codes	84
A description of each error code and possible solution is provided in the following tables:.....	85
Warranty Information.....	93

Regulatory Information

This section describes the tape autoloader compliance with safety and regulatory agency standards.



IMPORTANT

To comply with the following regulations and standards, the tape autoloader must be properly installed in an office or industrial environment with shielded cables and adequate grounding of the input power.

Device Standards

- ANSI Small Computer System Interface-2 (SCSI-2), X3.131 – 1994
- ANSI SCSI-3 Primary Commands, X3.301 - 1997
- ANSI Information and Technology. SCSI-3 Medium Changer Commands (SMC), NCITS.314:1998
- ANSI SCSI Parallel Interface-2 (SIP-2), X3.302:1998
- IEC 60297 Rack Standards

FCC (United States)

The computer equipment described in this manual generates and uses radio frequency (RF) energy. If the equipment is not installed and operated in strict accordance with the manufacturer's instructions, interference to radio and television reception might result.



**Tested To Comply
With FCC Standards**

This equipment complies with Part 15 of the FCC Rules. Operation is subject to the following conditions: (1) This device may not cause harmful interference, and (2) this device must accept any interference received, including interference that may cause undesired operation.

Part 15, Class A, of the FCC Rules, is designed to provide reasonable protection against radio and television interference in a residential installation. Although the equipment has been tested and found to comply with the allowed RF emission limits, as specified in the above cited Rules, there is no guarantee that interference will not occur in a particular installation. Interference can be determined by turning the equipment off and on while monitoring radio or television reception. The user may be able to eliminate any interference by implementing one or more of the following measures:

- Reorient the affected device and/or its receiving antenna.
- Increase the distance between the affected device and the computer equipment.
- Plug the computer and its peripherals into a different branch circuit from that used by the affected device.
- If necessary, consult an experienced radio/television technician for additional suggestions.

Perchlorate warning

California Best Management Practices Regulations for Perchlorate Materials: This Perchlorate warning applies only to products containing CR (Manganese Dioxide) Lithium coin cells. "Perchlorate Material-special handling may apply. www.dtsc.ca.gov/hazardouswaste/perchlorate".

Canadian Verification

This Class A digital apparatus meets all requirements of the Canadian Interference-Causing Equipment Regulations (ICES-003, Class A)

CE Statement

This product conforms to the following European Directive(s) and Standard(s): Application of Council Directives: 73/23/EEC, 89/336/EEC. Standards to which Conformity is declared: EN60950, EN55022, EN55024, EN61000-3-2, EN61000-3-3.

VCCI

This is a Class B product based on the standard of the Voluntary Control Council for Interference from Information Technology Equipment (VCCI). If this is used near a radio or television receiver in a domestic environment, it may cause radio interference. Install and use the equipment according to the instruction manual.

この装置は、情報処理装置等電波障害自主規制協議会（VCCI）の基準に基づくクラス B 情報技術装置です。この装置は、家庭環境で使用することを目的としていますが、この装置がラジオやテレビジョン受信機に近接して使用されると、受信障害を引き起こすことがあります。

取扱説明書に従って正しい取り扱いをして下さい。

Recycling and disposal



NOTE

Disposal of Waste Equipment by Users in Private Household in the European Union and Norway

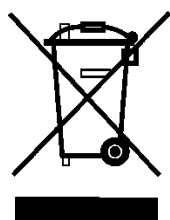

This symbol on the product or on its packaging indicates that this product must not be disposed of with your other household waste. Instead, it is your responsibility to dispose of your equipment by handling it over to a designated collection point for the recycling of waste electrical and electronic equipment. The separate collection and recycling of your waste equipment at this time of disposal will help to conserve natural resources and ensure that it is recycled in a manner that protects human health and the environment. For more information about where you can drop off your waste equipment for recycling, please contact your local city office, your household waste disposal service or the shop where you purchased the product.

Warnings and Symbols



IMPORTANT

All safety and operating instructions should be read before this product is operated, and should be retained for future reference. This unit has been engineered and manufactured to assure your personal safety. Improper use can result in potential electrical shock or fire hazards. In order not to defeat the safeguards, observe the following basic rules for its installation, use and servicing.



DANGER

High voltage!

Risk of electric shock.

Do not remove cover (or back). No user-serviceable parts inside. Refer servicing to qualified service personnel.



39 - 66 lbs
18 - 30 kg

DANGER

A danger condition due to the weight of the unit. Weight symbols are accompanied by an approximation of the product's weight.



CAUTION

A discharge of static electricity can damage static-sensitive devices or micro circuitry. Proper packaging and grounding techniques are necessary precautions to prevent damage.



NOTE

Provides additional information.

Document Revision

Title: SymplyPRO XTL 8 User Guide

Date: January 19th, 2026

Document Version: 1.2

Library Firmware: 6.20 / 2.90n

Library Boot Code: 0.82

About this guide

This guide is intended for system administrators and general users who need physical and functional knowledge of the SymplyPRO XTL 8 1U Autoloader.

This guide provides information about:

- Installing the SymplyPRO XTL 8 Autoloader.
- Configuring and operating the SymplyPRO XTL 8 Autoloader.
- Troubleshooting the SymplyPRO XTL 8 Autoloader.
- Upgrading and servicing the SymplyPRO XTL 8 Autoloader.
- Installing the Optional Remote Management Unit (RMU).
- Installing the SymplyPRO XTL 8 Autoloader in a rack.

COPYRIGHT STATEMENT

© 2024 SYMPLY. All rights reserved.

Your right to copy this manual is limited by copyright law. Making copies or adaptations without prior written authorization of SYMPLY is prohibited. SymplyPRO is a trademark in the U.S. and other countries. All other trademarks are the property of their respective companies.

LTO and Ultrium are trademarks of HP, IBM, and Quantum in the U.S. and other countries. All other trademarks are the property of their respective companies.

Introduction

The SymplyPRO XTL 8 Tape Autoloader provides a compact, high-capacity, low-cost solution for simple, unattended data backups and archives. This unique design houses up to 8 tape cartridges in a compact 1U form factor with easy access to tape cartridges via two removable magazines and a mail slot. The magazines can hold up to four (left magazine including mail slot) cartridges.

The SymplyPRO XTL 8 Tape Autoloader can support one half-height LTO tape drives either SAS or Fibre Channel (FC). The autoloader occupies one SCSI target address and uses dual LUNs for the tape drive and autoloader robotic. The SymplyPRO XTL 8 Tape Autoloader can be operated via Operator Control Panel (OCP) or via the Remote Management Unit (RMU).

SymplyPRO XTL 8 Tape Autoloader is compatible with most operating systems and environments that support the SAS or Fibre Channel (FC) interface. However, the autoloader requires either direct support from the operating system or a compatible backup application to take full advantage of its many features.

Preparing the host

For the best experience in using the SymplyPRO XTL 8 it is important to make sure that the host server or workstation is correctly configured.

Symply recommend you follow these general guidelines:

- To get optimum performance from your SymplyPRO XTL a SAS or Fibre Channel HBA is required in the host that can transfer data at a rate that supports the autoloader's maximum burst transfer speed.
- Make sure that your data protection application supports the SAS or Fibre Channel (FC) HBA installed in the host.
- Install a suitable HBA that supports LUN scanning and TLR.
- Depending on the server configuration, you may need to change the SCSI IDs of the autoloader.
- When the host server is powered on, install the software and/or driver(s) that are compatible with the autoloader. Data protection software packages may require additional software or licensing to communicate with the autoloader robotics.
- Confirm the host server's operating system recognized the autoloader.

For more information on verifying the connections consult the HBA and operating system documentation.

	IMPORTANT	Some host adapters that are also RAID controllers do not support tape libraries. It is important that the host adapters support TLR.
---	------------------	--

	TIP	Symply recommend ATTO SAS and Fibre Channel Host Adapters, they are available from Symply and our authorized resellers.
---	------------	---

SymplyPRO XTL 8 Hardware Overview

SymplyPRO XTL 8 Part Numbers

Part Numbers	Drive Generation	Host Interface	Maximum Native Capacity	Maximum Native Data Transfer
SYXTL-C08S1L7H2	LTO-7	2 x 6Gb SAS SFF-8088	48TB	300MB/Sec
SYXTL-C08S1L8H2	LTO-8	2 x 6Gb SAS SFF-8088	96TB	300MB/Sec
SYXTL-C08S2L9H2	LTO-9	2 x 12Gb SAS SFF-8644	384TB	300MB/Sec
SYXTL-C08F1L7H2	LTO-7	2 x 8Gb FC LC	48TB	300MB/Sec
SYXTL-C08F1L8H2	LTO-8	2 x 8Gb FC LC	96TB	300MB/Sec
SYXTL-C08F1L9H2	LTO-9	2 x 8Gb FC LC	384TB	300MB/Sec

Physical Specifications SymplyPRO XTL 8

Characteristic	Description
Rack requirements	Standard 19-inch rack with 1U of clearance
Number of Slots	8
Number of Mailslots	1
Drive Form Factor	Half-Height
Number of Drives	1
Drive Interface	SAS or Fibre Channel
MSBF w/o drive	500,000 hours
Dimensions (H x W x D)	45.6 x 444.5 x 789.5 mm (1.79 x 17.5 x 31.08 in)
Power Supply	Single 80W Module (110 to 240v)
Weight Without Media	11.4 Kg (25.13 lb)
Weight With Media (8 pieces)	13.1 Kg (28.66 lb)
Clearance Rear	Minimum of 154 mm (6.06 in)
Clearance Front	Minimum of 308 mm (12.12 in) – for mail slot Minimum of 600 mm (23.62 in)– for remove magazines
Clearance Side	Minimum of 50.8 mm (2 in)

Environmental Specifications SymplyPRO XTL 8

Environmental Factor	Recommended	Allowable	Non-Operating
Dry-Bulb Temperature	LTO-9 and LTO-10: 15 to 25 °C (59 to 77 °F) LTO-7 and LTO-8: 16 to 25 °C (61 to 77 °F)	LTO-9 and LTO-10: 15 to 30 °C (59 to 86 °F) LTO-7 and LTO-8: 16 to 30 °C (61 to 86 °F)	5 to 35°C (41 to 95°F)
Relative Humidity	LTO-9 and LTO-10: 20 to 50% (non-condensing) LTO-7 and LTO-8: 20 to 50% (non-condensing)	LTO-9 and LTO-10: 20 to 50% (non-condensing) LTO-7 and LTO-8: 20 to 50% (non-condensing)	20 to 80% (non-condensing)
Maximum Temperature Change	5 °C (41°F) / hour	5 °C (41°F) / hour	5 °C (41°F) / hour
Maximum Humidity Change	5% / hour	5% / hour	5% / hour
Temperature Limitation for Humidity Conditions	LTO-9 and LTO-10: Max Dew Point 22 °C (72 °F) LTO-7 and LTO-8 Wet Bulb Temperature <= 26 °C (79 °F)		
Maximum Altitude	3,048 m (10,000 ft)	3,048 m (10,000 ft)	12,192 m (40,000 ft)
Dust concentration	Less than 200 microgram / cubic metre		

Transport and Storage of Library and Data Cartridge

Condition	Environmental Specification
Short-term Storage condition	See operating conditions
Long-term Storage condition	See operating conditions
Shipping Conditions	5 to 45 °C (41 to 113 °F); 10% to 80% non-condensing. RH; 26 °C (72 °F) dew point maximum

<p>! IMPORTANT</p>	<p>Data cartridges stored at a temperature in excess of 52°C (125.6 °F) may suffer permanent damage. It is important that both temperature and humidity should be kept constant, as rapid changes in either are not good for the data cartridges or LTO drives.</p>
----------------------------------	---

SymplyPRO XTL 8 Front View

The front of the SymplyPRO XTL 8 is used to access the power button, Operator Control Panel (OCP), left and right magazines, LED's, and the mail slot.

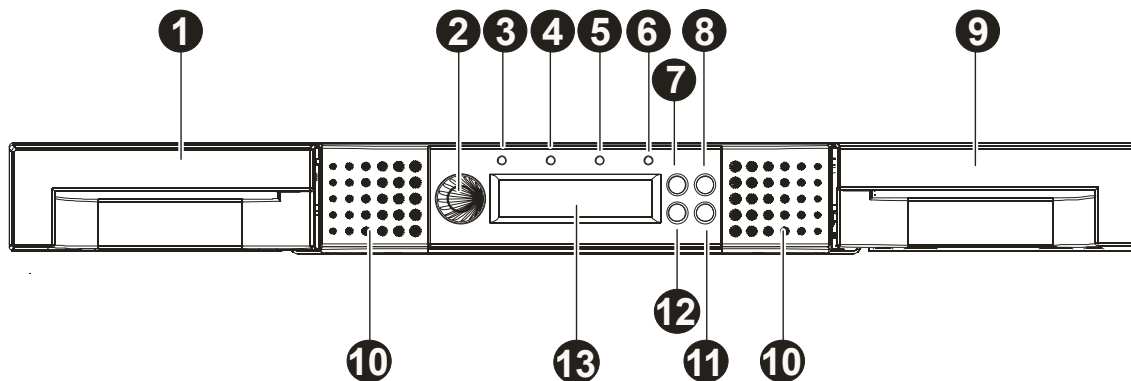

Number	Description
1	Left magazine with Mail slot
2	Power Button
3	Ready LED (Green)
4	Clean LED (Amber)
5	Attention LED (Amber)
6	Error LED (Amber)
7	Control key "Up" button [↑]
8	Control key "Cancel" button [X]
9	Right magazine
10	Air Vents
11	Control key "Down" button [↓]
12	Control key "Enter" button [↵]
13	OCP LCD Display

SymplyPRO XTL 8 Operator Control Panel (OCP)

The Operator Control Panel (OCP) consists of an LCD display, 4 push button switches, a power on/off button, and 4 status LEDs. The OCP screen displays actions and status information, menu items or error messages equivalent to the operation mode.

SymplyPRO XTL 8 OCP LEDs Guide

There are 4 LEDs located on the front of the autoloader above the LCD display.

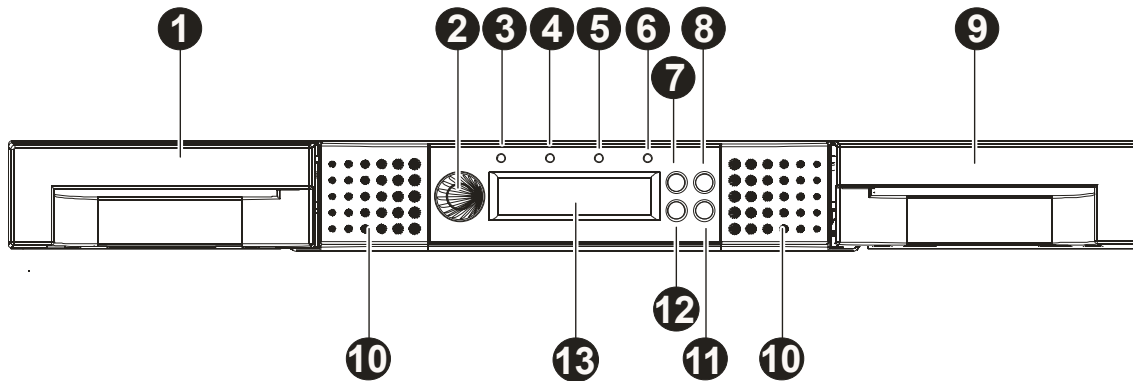

Number	LED	Colour	Description
3	Ready / Activity	Green	Illuminated when power is on. Blinking when there is tape or autoloader robotics activity.
4	Clean Drive	Amber	Illuminated when the tape drive has determined that a cleaning cartridge should be used. Cleaning is only necessary when the autoloader directs you to do so. Additional cleaning is not necessary. The LED will be turned off after the tape drive is cleaned successfully.
5	Media Attention	Amber	Illuminated if the autoloader has detected a condition that requires attention by the operator. Media might be bad, marginal or invalid. It will be cleared when all invalid cartridges have been exported from the tape autoloader.
6	Error	Amber	Illuminated if an unrecoverable tape drive or autoloader error occurs. A corresponding error message displays on the LCD screen (see for more information). It will be cleared when the error state is resolved.

SymplyPRO XTL 8 Push Button Guide

There are 4 buttons located on the front of the autoloader to the right-hand side of the LCD display.

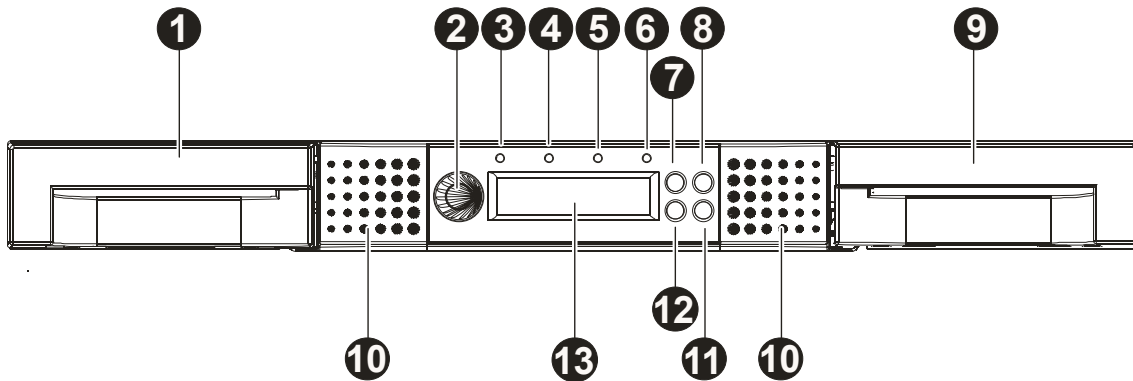

Number	Button	Description
11	Enter Button [↵]	The ENTER button to go to a sub menu or execute an action
7	Up Button [↑]	The UP button is used to navigate through menu items
12	Down Button [↓]	The DOWN button is used to navigate backward through menu item
8	Cancel Button [x]	The CANCEL button is used to cancel a user action and return to the last menu item
2	Power Button	Pressing the POWER ON/OFF button will initiate a controlled Power Down of the unit (soft power down)

SymplePRO XTL 8 Rear View

The rear of the tape autoloader provides access to SAS or Fibre Channel (FC) connectors, tape drive bays, the power connector, Ethernet, serial and the USB port.

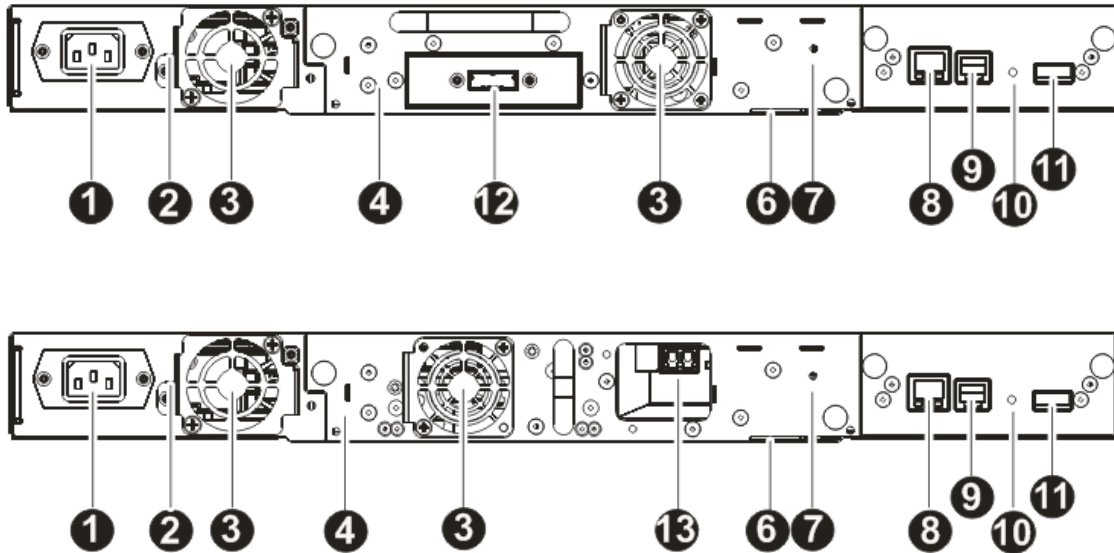

Number	Description
1	Power connector: The autoloader requires a 110/220 volt AC power connection
2	Shipping lock (storage location)
3	FAN Vent
4	Tape Drive Sled
6	Product ID Tag
7	Tape Drive LED
8	Ethernet Management Port
9	Service Port
10	Autoloader Controller LED
11	USB Port
12	SAS Connector (SFF-8008 or SFF-8644)
13	Fibre Channel Connector (LC)

SymplyPRO XTL 8 Internal View

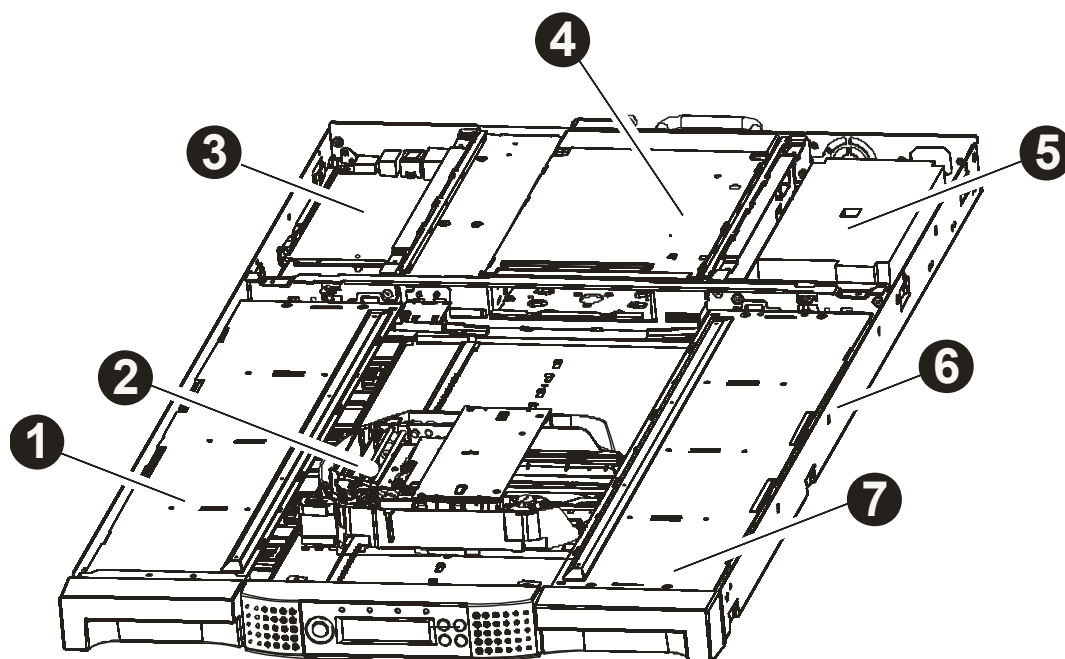

Number	Description
1	Left magazine
2	Robot and Barcode Reader
3	Autoloader Controller
4	Drive Sled
5	Power Supply
6	Chassis
7	Right magazine

Acclimatization Time for Autoloader and Data Cartridge

Acclimatisation is required if the SymplyPRO XTL has been stored or transported at a different temperature to the operating environment. As a baseline, allow **four hours** after unpacking for the library to reach ambient temperature.

If there is **no risk of condensation** (i.e., the air is dry and the unit is above the local dew point), you may bring the unit up to temperature more quickly by **powering it on for ~30 minutes** before use. Do **not** load tapes until the unit has stabilised.

If the SymplyPRO XTL is **hotter than the maximum operating temperature (30 °C / 86 °F)**, there is a risk that tape may adhere to the read/write head. In this case, allow the library and drives to **cool back within the operating range** before use.

For best results, store the SymplyPRO product **and** its LTO data cartridges **together for 24 hours** in the environment where they will be used. This helps temperature and humidity equalise, ensuring proper acclimatisation.

LTO Drive and Data Cartridge Compatibility Guide

	LTO-5 Data Cartridge	LTO-6 Data Cartridge	LTO-7 Data Cartridge	LTO-8 Data Cartridge	LTO-9 Data Cartridge
SymplyPRO LTO-7	Read Only	Read & Write	Read & Write	n/a	n/a
SymplyPRO LTO-8	n/a	n/a	Read & Write	Read & Write	n/a
SymplyPRO LTO-9	n/a	n/a	n/a	Read & Write	Read & Write

LTO-9 Media Optimization

Overview. LTO-9 media optimisation—also referred to as *characterization*—was introduced with LTO-9 drives and LTO-9 cartridges. Because LTO-9 writes many more, narrower tracks, the drive performs a one-time, per-cartridge calibration to establish a reference that its intelligent alignment system uses to optimise data placement. This improves write reliability and long-term media durability. (Not required when using LTO-8 media in an LTO-9 drive.)

Key points

- **Automatic on first load.** Optimisation runs the first time an LTO-9 cartridge is initialised in any LTO-9 drive.
- **One time per cartridge.** Once completed, the cartridge can be used in any compatible drive without repeating optimisation.
- **Typical duration.** Expect ~**40 minutes** on average. Most complete within **60 minutes**; some may take up to **2 hours**.
- **No impact from duration variance.** The time taken has no effect on cartridge performance or functionality.
- **Do not interrupt.** Let the process complete before starting backup or archive jobs.
- **Pre-optimised media from Symply.** All LTO-9 media included in-box with Symply LTO-9 products ships **pre-optimised**.
- **Available through resellers.** Symply-supplied LTO-9 media is available **with or without** pre-optimisation via our authorised reseller network.



TIP

If you're introducing non-pre-optimised media into a new environment, consider pre-loading cartridges during a maintenance window so optimisation completes ahead of scheduled jobs [[Using the LTO-9 New Media Initialization \(Optimization\) Wizard](#)]

Installing the SymplyPRO XTL 8

Unpacking the SymplyPRO XTL 8

Please inspect the unit for shipping damage. If there is damage, do not install the unit, report the damage immediately by contacting your place of purchase.

Caution should be used whenever lifting the SymplyPRO XTL 8 in and out of the shipping carton, make sure that the working area around you is free from obstructions.

- Carefully unpack the SymplyPRO XTL 8.
- Remove the shipping materials from the top of the autoloader.
- Remove the two rack rails and set aside.
- Carefully lift the autoloader out of the carton, remove the bag from the autoloader.
- Save the packaging materials for future use.

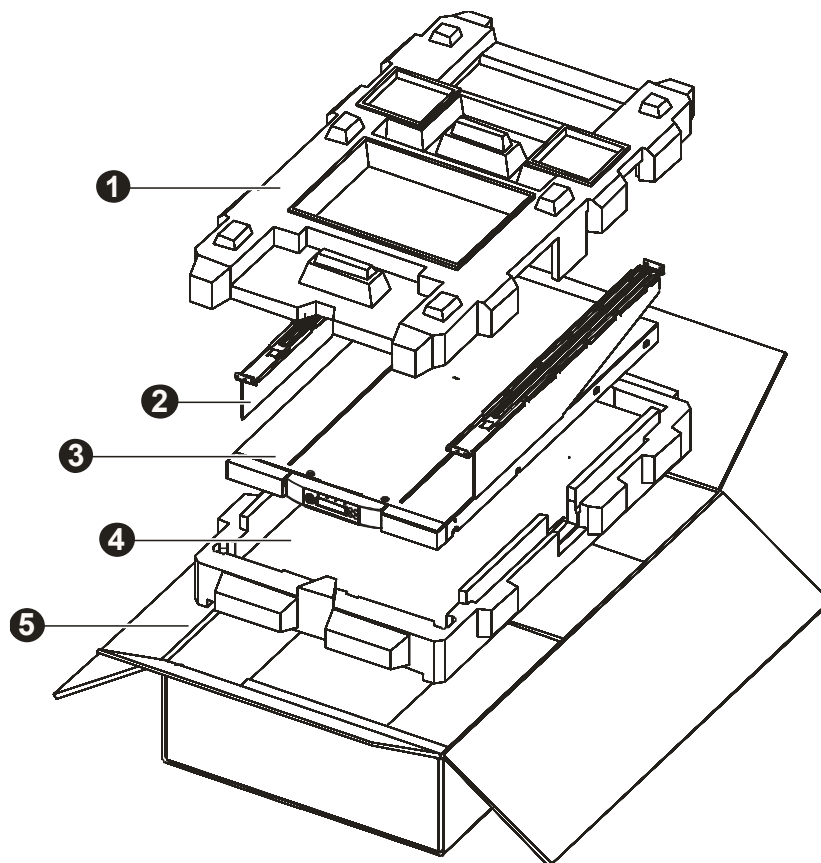

Number	Description
1	Top Packing Shell
2	Rack rails
3	Autoloader
4	Bottom Packing Shell
5	Shipping Carton

What's in the box?

Item	QTY	Description
SymplyPRO XTL 8	1	1U 8 Slot Autoloader with Single Fixed PSU
Rack Kit	1	<ul style="list-style-type: none"> ▪ 2 rack mount rails. ▪ 2 mounting brackets. ▪ 6 x M3 torx screws to fix the mounting brackets (9.5mm square holes) ▪ 6 x M3 torx screws to fix the mounting brackets (9.5mm round holes) ▪ M5 screws to secure the mounting brackets to the rack.
LTO Clean Cartridge	1	SymplyLTO Media - Ultrium Universal Cleaning Cartridge, with barcode
Ethernet Cable	1	Ethernet Cable (for management port)
Data Cable Optical	1	FC Units Only – 1 x 3m OM4 LC-LC Optical Cable
Data Cable SAS	1	SAS Units Only – 1 x 2m SAS Cable <ul style="list-style-type: none"> ▪ LTO-7 & LTO-8 include SFF-8080 -to- SFF-8644 ▪ LTO-9 include SFF-8644 -to- SFF-8644
Power Cable	1	2 m (6.5 ft) IEC power cord for local region
Welcome Card	1	Information Card Please Read Carefully
Shipping Carton	1	Please retain shipping carton and packaging for warranty purposes

Location Requirements

- The library was designed for rack installation only.
- Rack installations must use the provided rack rails.
- Select a location with access to the host server.
- Choose a location that meets the criteria in the table below.

Criteria	Definition
<i>Rack Requirements</i>	<i>Standard 19-inch rack (minimum depth of 800 mm / 31.49 in) with an appropriate # of U's (Rack Units) of clearance for the planned module quantity</i>
<i>Rack Space Requirements</i>	<i>1U</i>
<i>Room Temperature</i>	<i>Allowable: 10 - 30 °C (50 - 86 °F)</i>
	<i>Recommended: 10 - 25 °C (50 - 77 °F)</i>
<i>Power Source</i>	<ul style="list-style-type: none"> • <i>AC Power Voltage: 100-240 VAC</i> • <i>Line Frequency: 50-60 Hz</i> • <i>Library Located near AC Outlet(s)</i> <p><i>The AC power cord is the library's main AC disconnect device and must always be easily accessible.</i></p>
<i>Air Quality</i>	<ul style="list-style-type: none"> • <i>Place the library in an area with minimal sources of particulate contamination.</i> • <i>Avoid areas near frequently used doors and walkways, stacks of supplies that collect dust, printers, and smoke-filled rooms.</i> • <i>Excessive dust and debris can damage tapes and tape drive.</i> • <i>Less than 200 microgram / cubic metre.</i>
<i>Humidity</i>	<i>Recommended: 20 - 50% RH non-condensing</i>
	<i>Allowable: 20 - 80% RH non-condensing</i>

	CAUTION	The power source must be connected to a protective earth ground and comply with local electrical codes. Improper grounding may result in an electrical shock or damage to the unit. Failure to do so may cause injury or damage the unit. If you are using a rack, be careful not to exceed the power capabilities of the rack.
---	----------------	---

SAS Configuration Requirements

Serial Attached SCSI (SAS) is a point-to-point storage interface used for devices such as LTO tape drives and libraries. Because SAS links are direct connections rather than a shared parallel bus, you don't have to configure traditional SCSI bus IDs; however, the SCSI protocol (and **LUNs**) still apply over SAS.

Requirements and notes

- **Use a true SAS HBA (not a RAID controller).** Fit a host bus adapter with **external SAS** ports that supports **multiple LUNs** and **LUN scanning** so the OS can discover both the tape drive **and** the library robotics. Many RAID controllers do not expose devices correctly for tape.
- **LUN layout.** SymplyPRO XTL presents a single target per drive with **dual LUNs: LUN 0 = tape drive, LUN 1 = library robotics.**
- **Lane/port capacity.** A typical external SAS port is a **x4 wide** link (four lanes). An LTO tape drive uses **one lane**, so a single HBA port can service **up to four drives** when cabled appropriately (e.g., via a 1→4 breakout or SAS expander). If you connect one drive with a single end-to-end cable, only **one lane** is used, and the remaining lanes are idle.
- **Cabling.** Use certified external mini-SAS / mini-SAS HD cables that match the HBA and device connectors. Keep within the HBA's supported cable length and generation (6/12/24 Gb SAS).



TIP

For best results, use an IT-mode/initiator-class SAS HBA, enable **LUN scanning**, and verify in the OS that both a **Tape drive** and a **Medium changer** device are present before configuring your backup application.

Supported speeds by drive generation are shown in the table below:

LTO Generation	Supported Speeds
LTO-7	1.5 Gbps, 3 Gbps, 6 Gbps
LTO-8	1.5 Gbps, 3 Gbps, 6 Gbps
LTO-9	3 Gbps, 6 Gbps, 12 Gbps
LTO-10	3 Gbps, 6 Gbps, 12 Gbps



CAUTION

Always use a high-quality SAS cable. The library has one or more SAS connectors on each SAS tape drive. SAS connectors are keyed. Do not force a SAS cable's SAS connector into the tape drive as it might be keyed differently.

- **Unique identifier.** Each SAS tape drive is identified by a **World Wide Name** (WWN, also called **WWID**). In SymplyPRO XTL, the library assigns the WWID to the **drive bay**, so if a drive is replaced the **same WWID is reassigned** to the new drive in that bay.
- **OS tracking per channel.** The operating system associates the drive’s WWID with the **specific HBA channel** it was discovered on. With a fan-out (breakout) cable, each connector corresponds to a separate HBA channel.
- **Keep channel placement stable.** After initial discovery, keep each drive on the **same fan-out leg/channel** to preserve the OS association (WWID ↔ HBA channel). Moving a drive to a different channel can cause the OS or backup software to treat it as a **new device**, potentially requiring reconfiguration.



TIP Label the fan-out connectors (e.g., A/B/C/D) and match them to drive bay numbers to maintain consistent cabling and predictable device paths.

Fibre Channel Configuration Requirements

The Fibre Channel (FC) tape drive can be connected directly to the server with a Host Bus Adapter (HBA) or through a storage area network (SAN).

The installation requires one Fibre Channel cable for each tape drive. The tape drives all utilize an LC-style connector. Some drives will have two FC ports, but only one cable connection is needed per drive. The cable should always be connected to Port A.

Supported speeds by drive generation are listed in the table below:

LTO Generation	Supported Speeds
LTO-7	2 Gbps, 4 Gbps, 8 Gbps
LTO-8	2 Gbps, 4 Gbps, 8 Gbps
LTO-9	2 Gbps, 4 Gbps, 8 Gbps
LTO-10	8 Gbps, 16 Gbs, 32 Gbs

Removing the shipping lock

! **IMPORTANT** The shipping lock, which prevents the robotic transport mechanism from moving during shipment, must now be removed before the autoloader is powered on

i **NOTE** The shipping lock is held in place with label and is in the top centre of the autoloader. After the shipping lock is removed, it should be stored on the rear panel right side (next to power connector) of the autoloader for future use.

To remove and store the shipping lock:

- 1) Remove the yellow label that is securing the lock to the top of the autoloader, and then remove the lock.

Shipping lock and label.

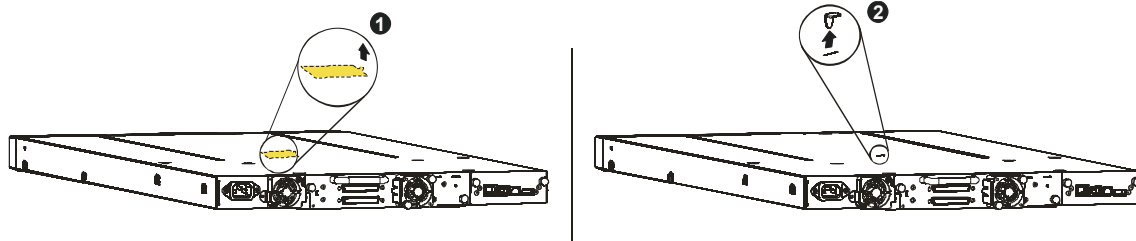

- 2) Store the shipping lock next to power supply.

Shipping lock secured next to the power supply.

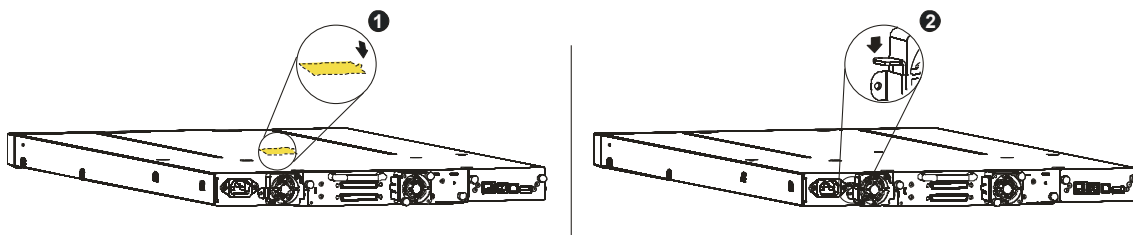

! **IMPORTANT** If you need to transport the autoloader, it is essential that the shipping lock and label is replaced on the top cover to prevent damage during shipping.

Rack mounting the autoloader

The autoloader easily installs into a standard 19" rack system taking up 1U of space. The SymplyPRO XTL 8 tape autoloader weighs 13.1 kg (29 lbs) with 8 cartridges.

To rackmount the autoloader the following tools are required:

- #3 Phillips screwdriver
- T10 Torx screwdriver

There are two sets of eight M6 screws in the accessory package that came with the autoloader. The type of rack that you have will determine the type of M6 screw that you will use.

 <p>WARNING</p> <p>39 - 66 lbs 18 - 30 kg</p>	Risk of personal injury or damage to the autoloader due to the weight! Always remove all tapes to reduce the overall weight of the autoloader. Always observe local health and safety requirements and guidelines for manual material handling.
---	---

To install the autoloader in a rack:

- 1) Determine the location in your rack for your autoloader to be installed and, using a pencil, mark the location on each vertical rail in your rack.
- 2) Using the appropriate M6 screws for your rack type, and a #3 Phillips screwdriver, secure one rail to each side of the rack in your chosen rack location. Secure both the front and back of each rail to the rack. The rails extend to fit a variety of rack depths. The correct orientation of the left and right rails is shown in the figure below.

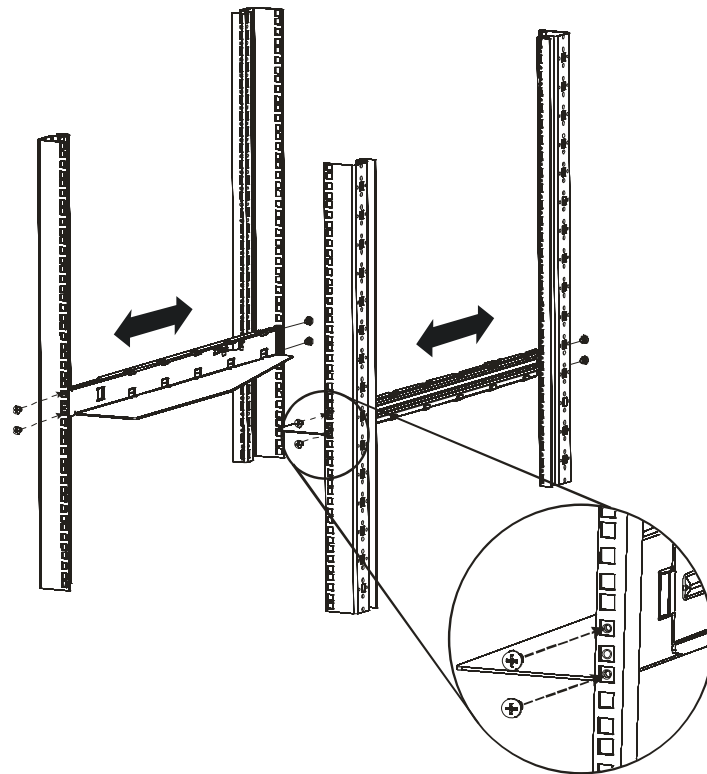

- 3) Using the Torx screwdriver, remove the screw on each side of your autoloader. Shown in the figure below.

Installing the mounting brackets and guide pulleys.

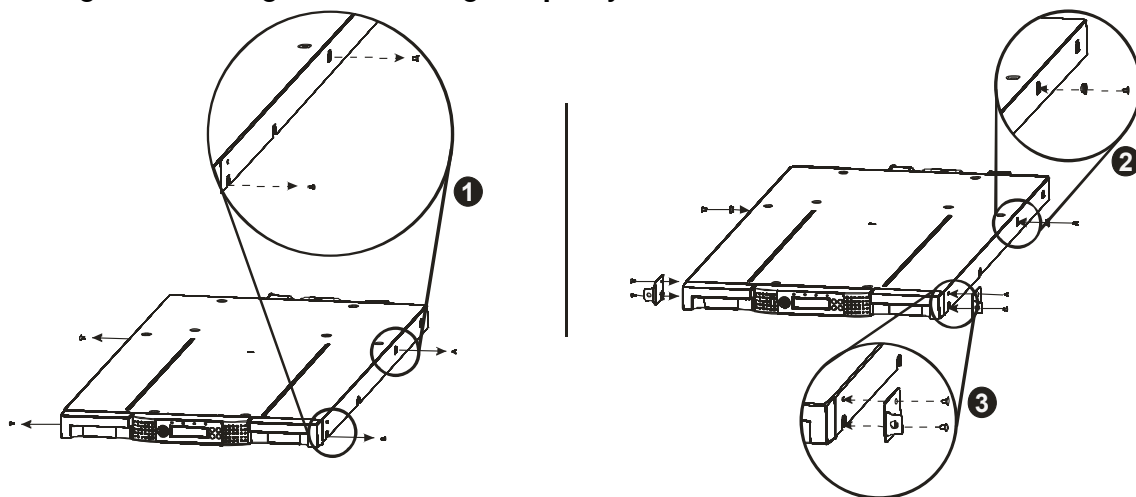

- 4) Install the autoloader guide pulleys on each side of the autoloader using the 2 Torx screws included in the rack kit (step 2).
- 5) Install the mounting brackets of the autoloader using the 4 Torxs screws included in the rack kit (step 3).
- 6) With autoloader guide pulleys and mounting brackets installed, slide the autoloader onto the rails.
- 7) Secure the autoloader to the rack using a 3# Phillips screwdriver placed through the small holes in the mounting bracket to tighten the M5 screw on each side of the autoloader.

Securing the autoloader to the rack.

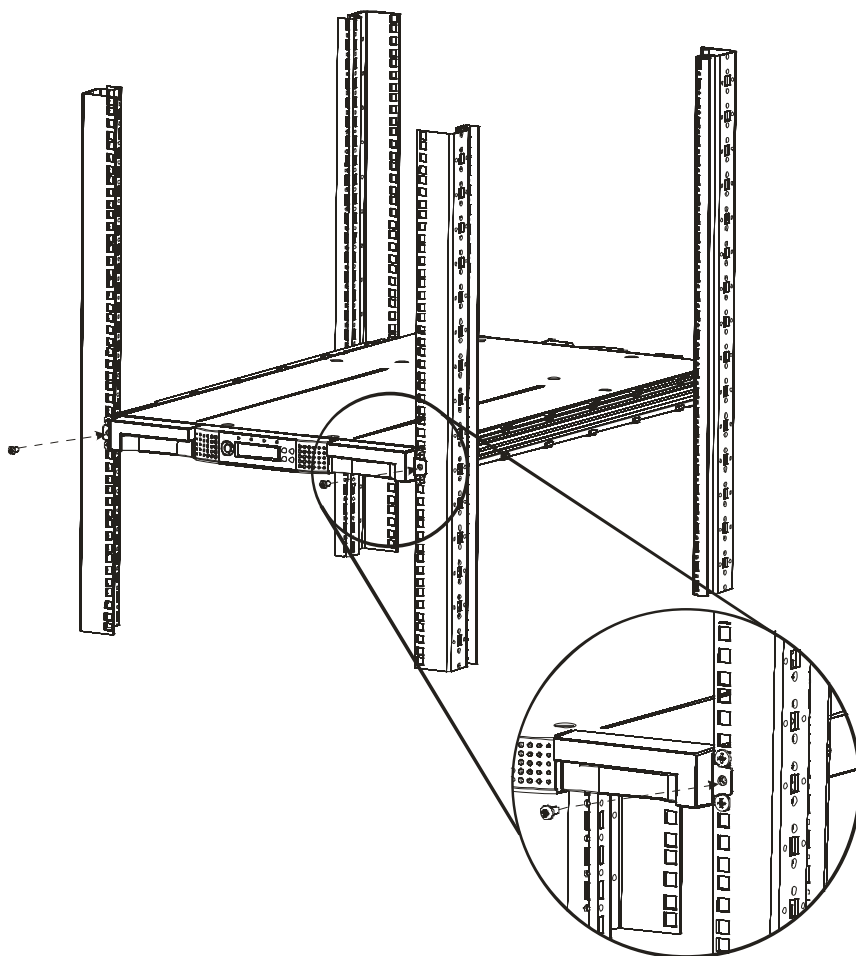

User operation of the SymplyPRO XTL 8

Default Username, Password and IP Configuration

Remote Management Unit (Web Interface) Credentials

Username	Description	Password
Guest	Standard User	systd
Admin	Administrator User	syadm
Service	Service User	sysrv

Default IP Address

Management Port (GbE RJ45)	
IP Address	DHCP Default

The management port is set to DHCP, the resolved IP address can be accessed via the OCP display.

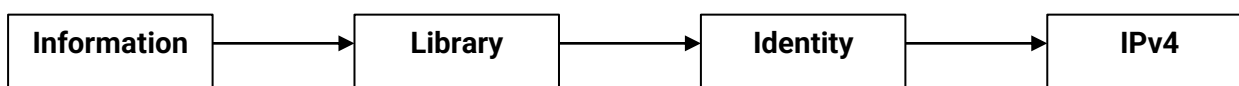

Operator Control Panel (OCP) Credentials

Username	Description	PIN
Guest	Standard User	0000
Admin	Administrator User	0000
Service	Service User	0000

Before power on the SymplyPRO XTL

Before powering on the system, ensure that none of the ventilation holes, or fans are blocked, that there are no obstructions around the system blocking airflow, that the environment is within the specified operating conditions and that acclimatization time has been allowed for both the autoloader and the media.

- Ensure the LTO drive is correctly installed in the autoloader.
- **Ensure the shipping lock has been removed** (and stored for future use).
- Connect the LTO drive to the host computer.
- Connect the management port of the autoloader to the host computer.
- Connect the mains power.
- Power on the SymplyPRO XTL 8.

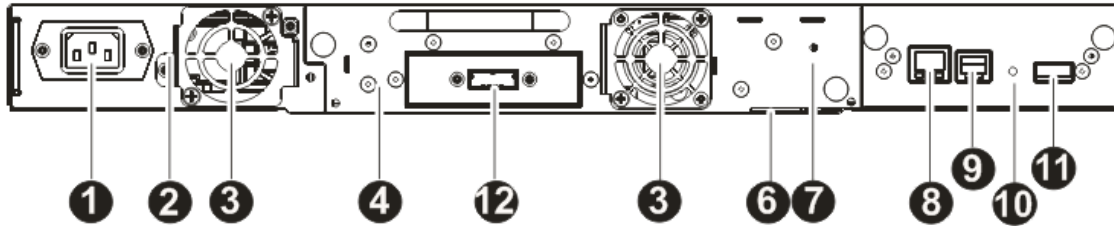

Number	Description
1	Power Supply Module
8	Ethernet Management Port
2	Shipping Lock
12	SAS or FC Host Ports



DANGER

Only use approved power cords! Not doing so can result in the following:

- not meeting individual country specific safety requirements.
- insufficient conductor amp capacity that could result in overheating with potential personal injury and/or property damage.
- an unapproved power cord could fracture resulting in the internal contacts being exposed, which potentially could subject the user to a shock hazard.



NOTE

Symply disclaims all liability in the event a non-manufacturer approved power cord is used.

Connecting Data Ports on the Tape Drive Modules

Connecting Data Ports on SAS Drive module

All the SymplyPRO XTL Tape Drive Modules have dual ports. Port A and Port B. **When connecting to the host please ensure that the host is connected to Port A only.**

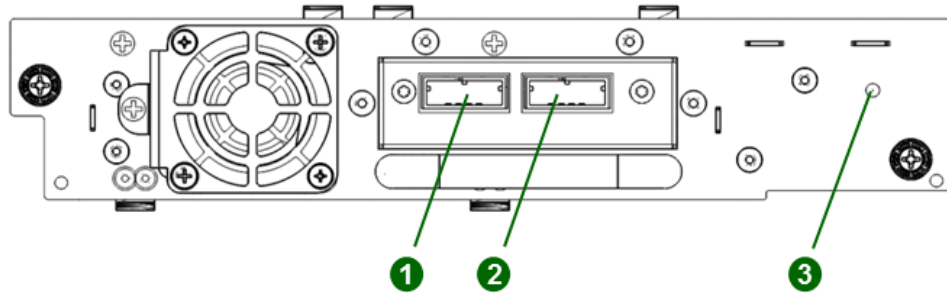

Number	Description
1	Port A
2	Port B
3	Tape Drive Power LED, Green

Connecting Data Ports on FC Drive module

All the SymplyPRO XTL Tape Drive Modules have dual ports. Port A and Port B. **When connecting to the host please ensure that the host is connected to Port A only.**

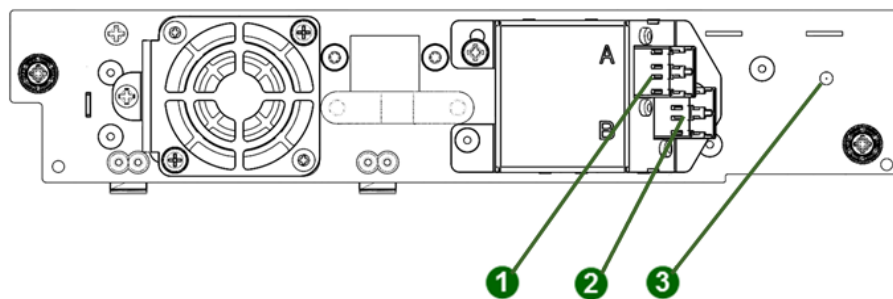

Number	Description
1	Fibre Channel Port A
2	Fibre Channel Port B
3	Tape Drive Power LED, Green

Power On/Off the SymplyPRO XTL

Part of the Operator Control Panel (OCP) is the Power On/Off button. Pressing this button will initiate a controlled Power Down of the unit (soft shutdown). The following operations will take place before the unit shuts down completely:

- The display indicates with an appropriate message that the shutdown is in progress.
- The autoloader controller finishes all ongoing autoloader and drive activities.
- The robotics is moved to its home position.
- The autoloader controller switches off the power supply's secondary side.
- To abort the shutdown process, the user has to press Cancel within the first 3 seconds.



NOTE

The shutdown process may be aborted by pressing Cancel within the first 3 seconds



IMPORTANT

Never remove power from the SymplyPRO XTL while a data cartridge is loaded in a drive. If the SymplyPRO XTL is powered off while a data cartridge is installed, then when the system is powered on again, the system will perform a much more intensive POST while the system verifies the integrity of the data on the tape. This extended POST process can take up to 10 minutes.

Power-On Display

When the autoloader device powers up, or resets, it goes through several internally controlled processes that allows it to get initialized and running. These processes are called Power-On-Self-Test (POST).

When the autoloader finishes coming online, it will display the current device status for a defined time or until a key is pressed.

After this initial status screen, the home screen will be shown until a key is pressed. This home screen shows the overall health of the autoloader, indicating the status of the robotic and the connected drives.



NOTE

The POST sequence and takes approximately 5 minutes.

Power on LED Sequence

All LEDs are displayed during Power Up and Reset sequences. Upon power up or software Reset, the autoloader will illuminate all LEDs as soon as POST allows. This will help the User to verify if all LEDs are functional. When initialization starts, all LEDs will be extinguished and the Ready/Activity LED will flash at a reasonable rate of approximately 1-second per cycle, 50% duty cycle. When the mechanical initialization is complete, the Ready/Activity LED will stop flashing and be constantly illuminated.

If a failure occurs, the Ready/Activity LED will be turned off, and the Error LED will be illuminated. The OCP will also display an appropriate error code to help identify the failure.

The following are additional operational details of LEDs:

- The "Ready/Activity" LED will be lit any time the unit is powered on and functional (i.e. passed power-on self-test). The Ready/Activity LED will blink whenever there is tape autoloader or drive activity. This LED will also blink when the unit is Offline.
- The "Clean" LED will only be lit when a cleaning REQUIRED has been issued by the drive. The LED will be turned off again after a successful drive cleaning operation.
- The "Media Attention" LED will indicate that there is a piece of media which is bad/marginal, or invalid. The LED will be cleared when all marginal and invalid cartridges have been exported from the tape autoloader.
- The "Error" LED will be lit when there is an unrecoverable (i.e. hard) drive or tape autoloader failure. This will happen at the same time as the hard error message is displayed on the screen and the LED will remain lit until the error state is resolved.

Different Operating Modes of the SymplyPRO XTL 8

There are two basic modes that the OCP operates in.

- User Interaction Mode
- System Drive Mode

First is the User Interaction Mode. This mode is employed when a user is controlling the autoloader via the buttons on the OCP on the front of the autoloader.

The second mode is the System Driven Mode. This is the usual mode of operation, when the autoloader is controller via backup or archive software running on the host server or workstation. In this mode, the OCP displays status associated with the actions that were caused from commands issued via the Drive's interface. Actions like Loading, Rewinding or Moving tape will be displayed.

When an OCP button is pressed and released, the OCP automatically transitions to User Interaction Mode. User Interaction mode will continue until 3 minutes after a user stops pushing buttons, or the requested robotic action stops - whichever is longer. At this time the OCP will return to System Driven Mode.

The SymplyPRO XTL 8 includes a user security feature, which when activated restricts the User Interaction Mode access to the Information and Login menu item, until a login with correct PIN is entered.

Operator Control Panel (OCP) Philosophy

Any OCP operation must obey some basic rules. These rules of operation constitute a 'philosophy'.

- Any operational conflict between commands received via the drive interface, or Remote Management Unit (RMU) and those entered via the front panel (OCP) are avoided with a reservation mechanism on a 'first-come, first-served' basis. Any reservation by OCP is cancelled by an OCP logout or the timeout, which cancels the User Interaction Mode, and makes the autoloader available for reservation from the RMU.
- The autoloader firmware will not allow a user to select an impossible request. Those situations will include, but are not limited to:
 - Moving a cartridge from any source to a full slot
 - Moving a cartridge from an empty slot
 - Loading a cartridge from any source to a full drive
 - Unloading a cartridge from an empty drive

- Any error detected by the autoloader or drive controller and not recoverable through predetermined firmware algorithms will be considered as fatal. An error code will be displayed on the LCD, and the error LED will become illuminated. The error code will remain on the OCP until a push button is pressed, which will cause the OCP to return to the Home Screen.
- Numeric error codes are only used for unrecoverable, fatal errors, otherwise text status messages are provided.

OCP Input Modes

There are several modes to enter values in the different menu items on the OCP. These values are selectable predefined values, toggle values (e.g. On/Off) and numerical values like network addresses.

Selectable predefined values

After navigating to the menu item, the various predefined values can be selected with the “UP” and “DOWN” button. As soon as the display shows the correct value it may be confirmed by pressing the “ENTER” button.

Toggle values

Toggle values are used to switch between two different states like On and Off. After navigating to the menu item, the display shows the actual state. Pressing the “ENTER” button will switch to the possible new state. Pressing “ENTER” a second time will take over this new state.

Numerical values

Numerical values are needed for network addresses, PIN entries, and other configuration entries. After navigating to the menu item to be changed, the actual value will be displayed, and the cursor stays on the first digit. The value may be incremented / decremented with the “UP” and “DOWN” button. After pressing the “ENTER” button the cursor is set to the next editable digit. It can be changed in the same way. After pressing the “ENTER” button at the last digit the complete entry will be stored. Pressing the “CANCEL” button will cancel the whole edit process, and the old value is valid again.

Flow Chart for the OCP Menu

OCP Status Information

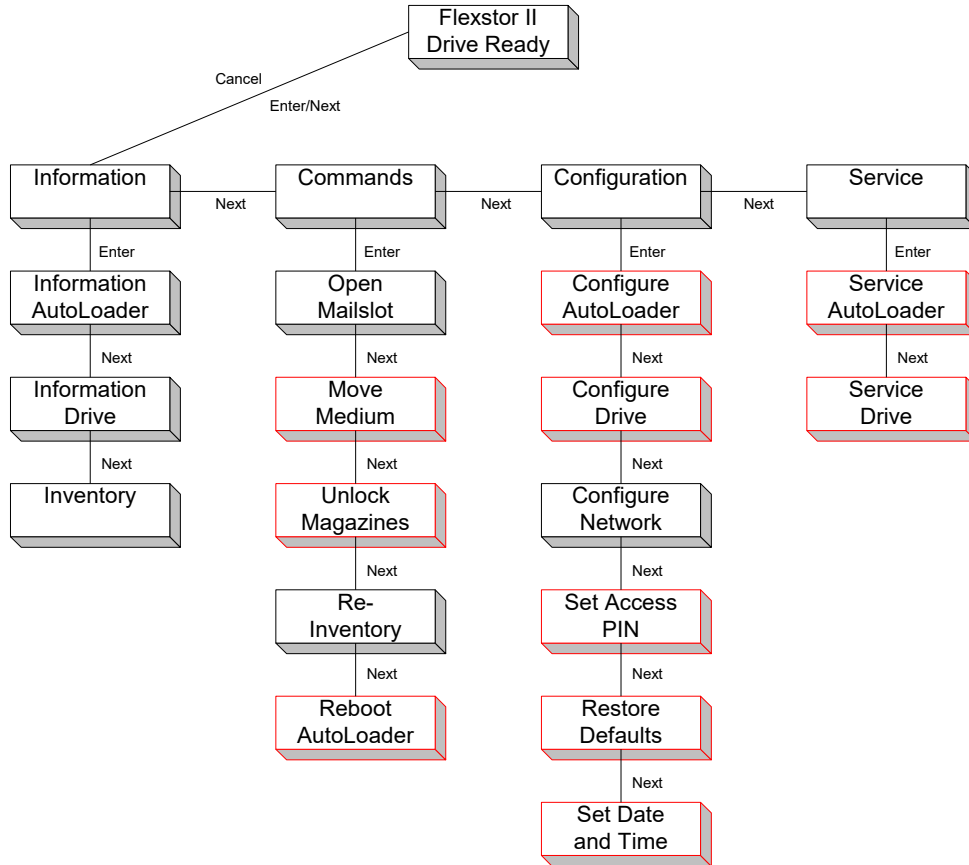

OCP Status Information (Continued...)

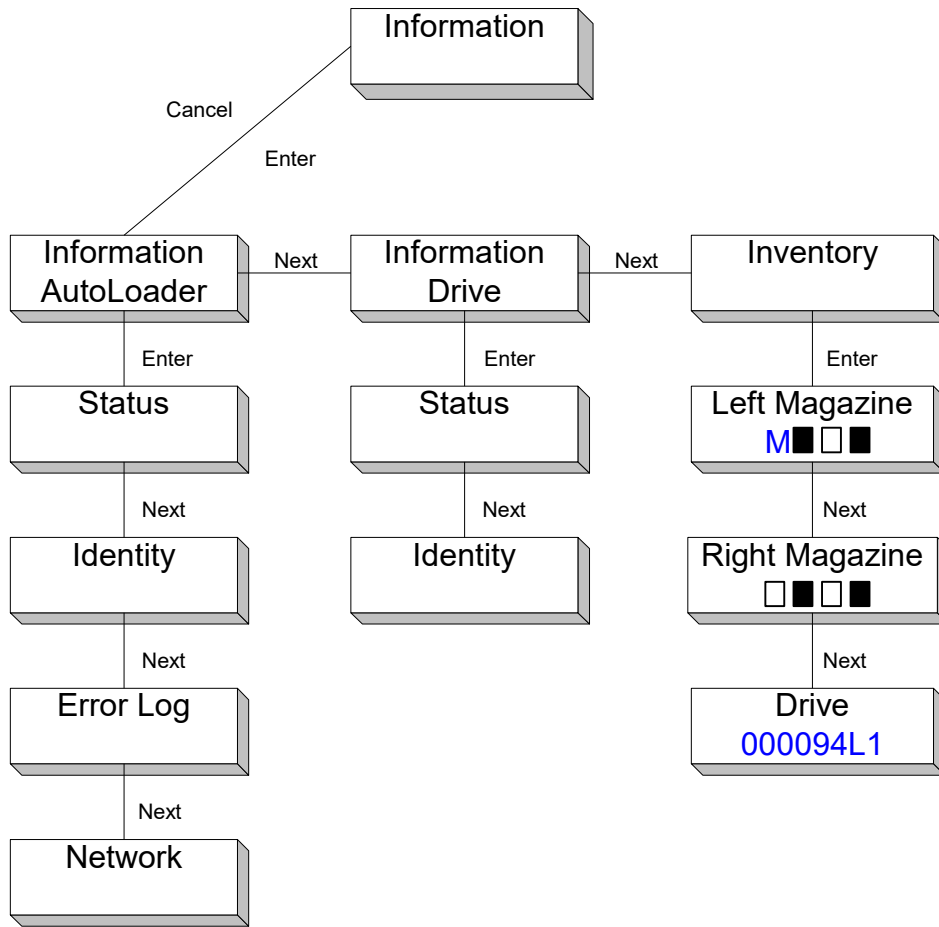

OCP Status Information (Continued...)

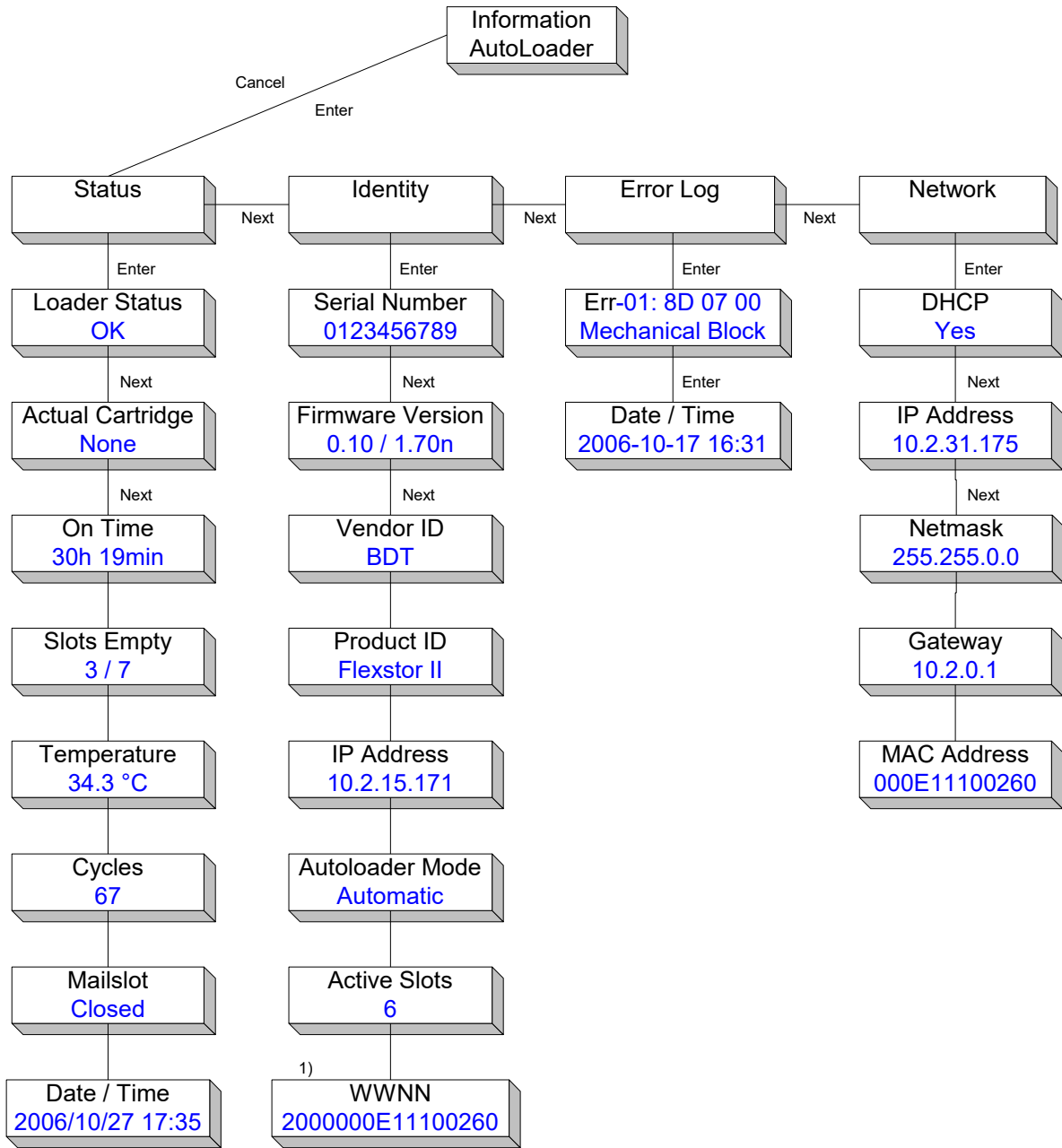

1) menu entry is only displayed if a fiber channel drive was found

OCP Status Information (Continued...)

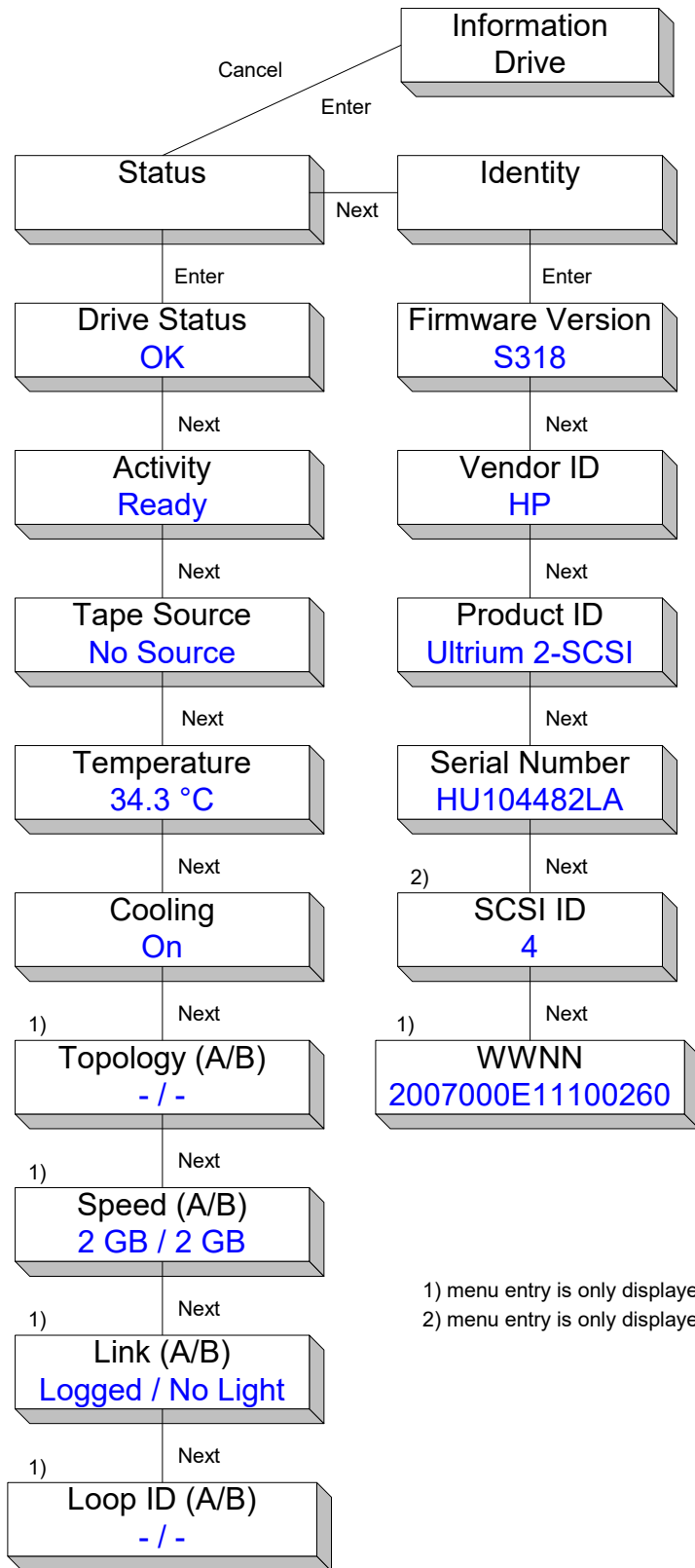

- 1) menu entry is only displayed if a fiber channel drive was found
- 2) menu entry is only displayed if a SCSI drive was found

OCP Status Information (Continued...)

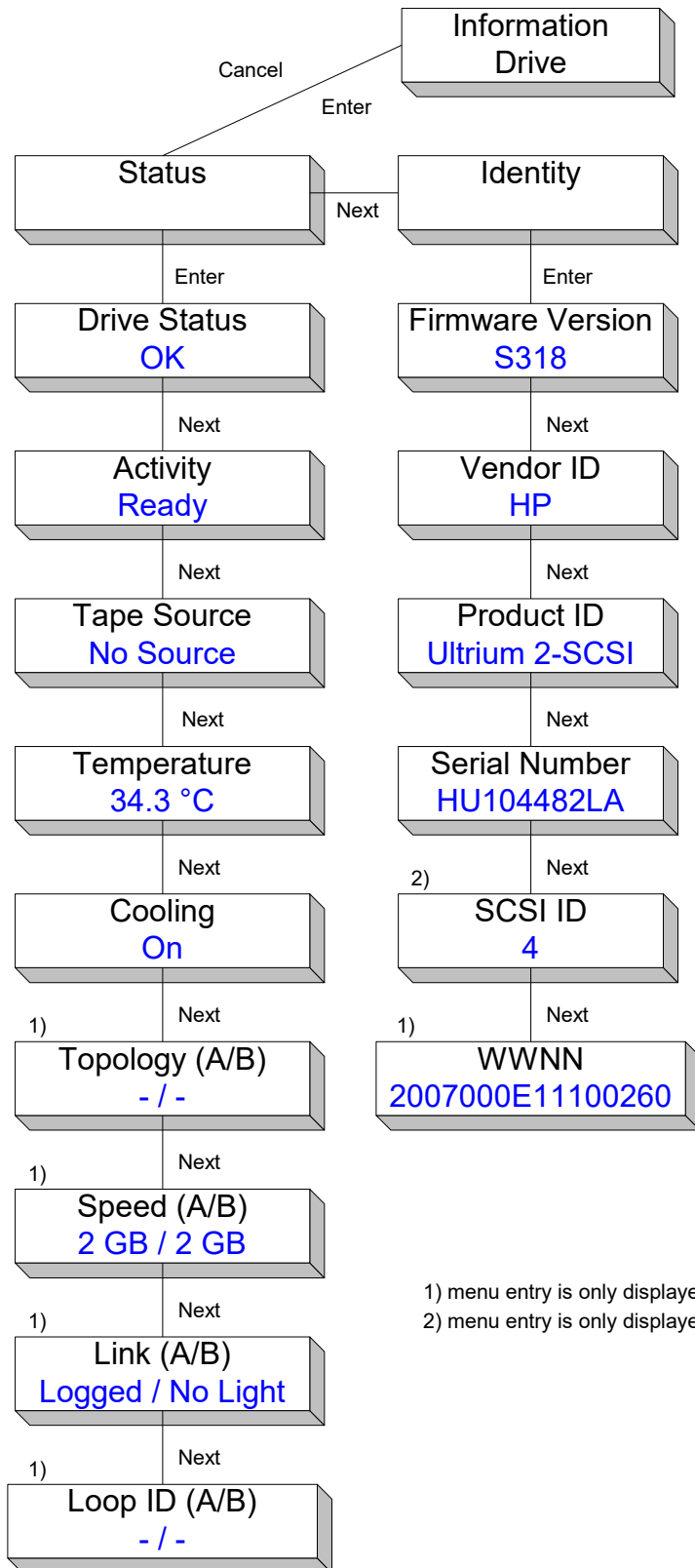

- 1) menu entry is only displayed if a fiber channel drive was found
- 2) menu entry is only displayed if a SCSI drive was found

OCP Inventory

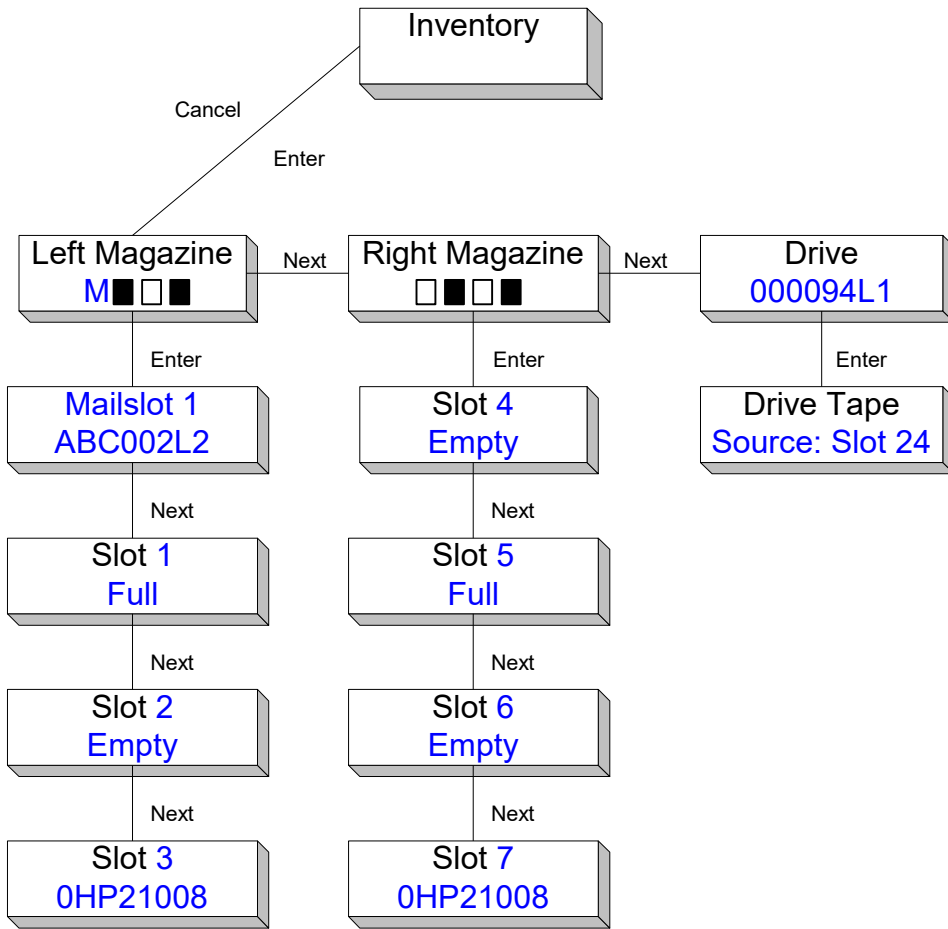

OCP Commands

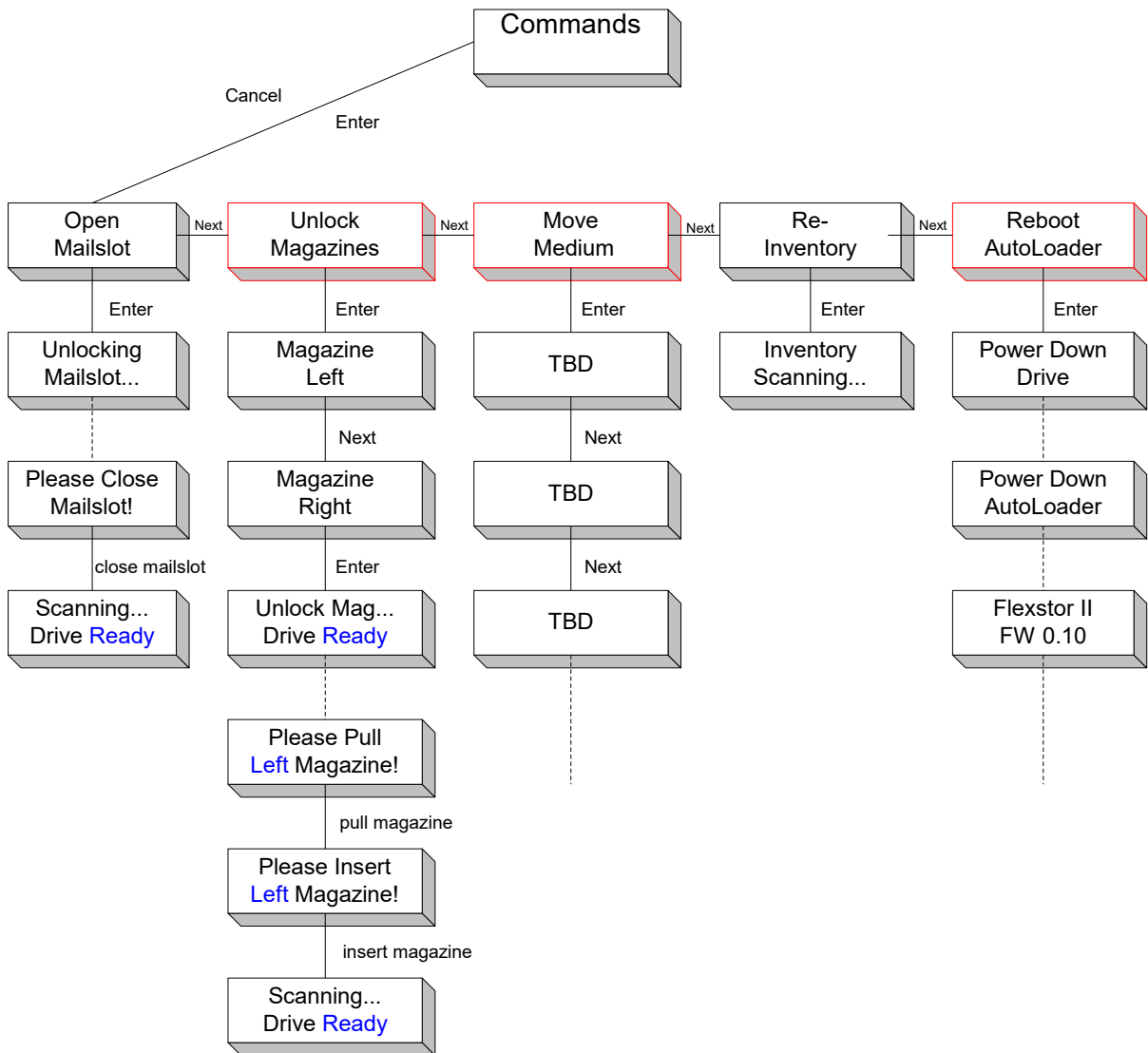

OCP Configuration

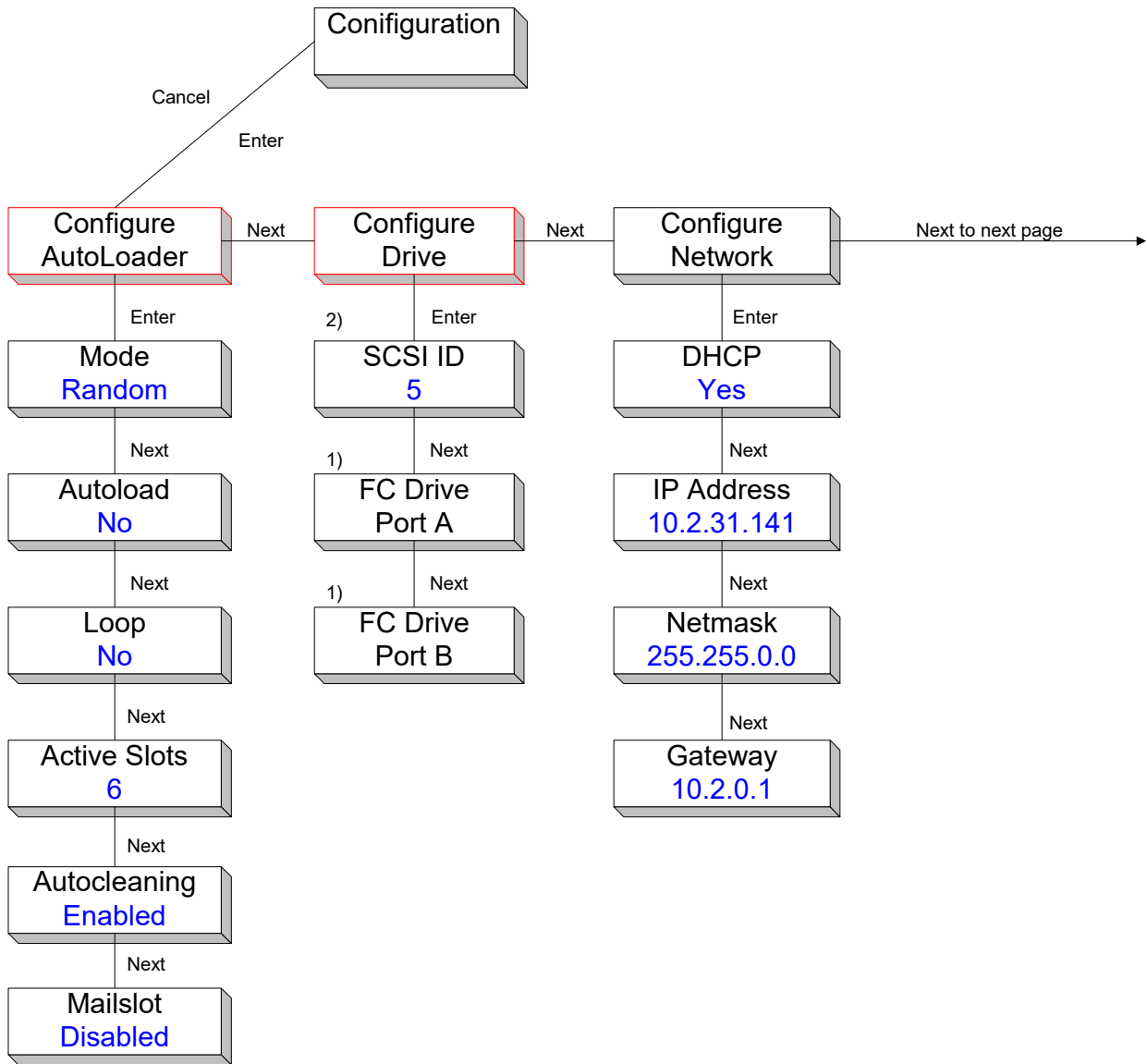

- 1) menu entry is only displayed if a fiber channel drive was found
- 2) menu entry is only displayed if a SCSI drive was found

OCP Configuration (Continued...)

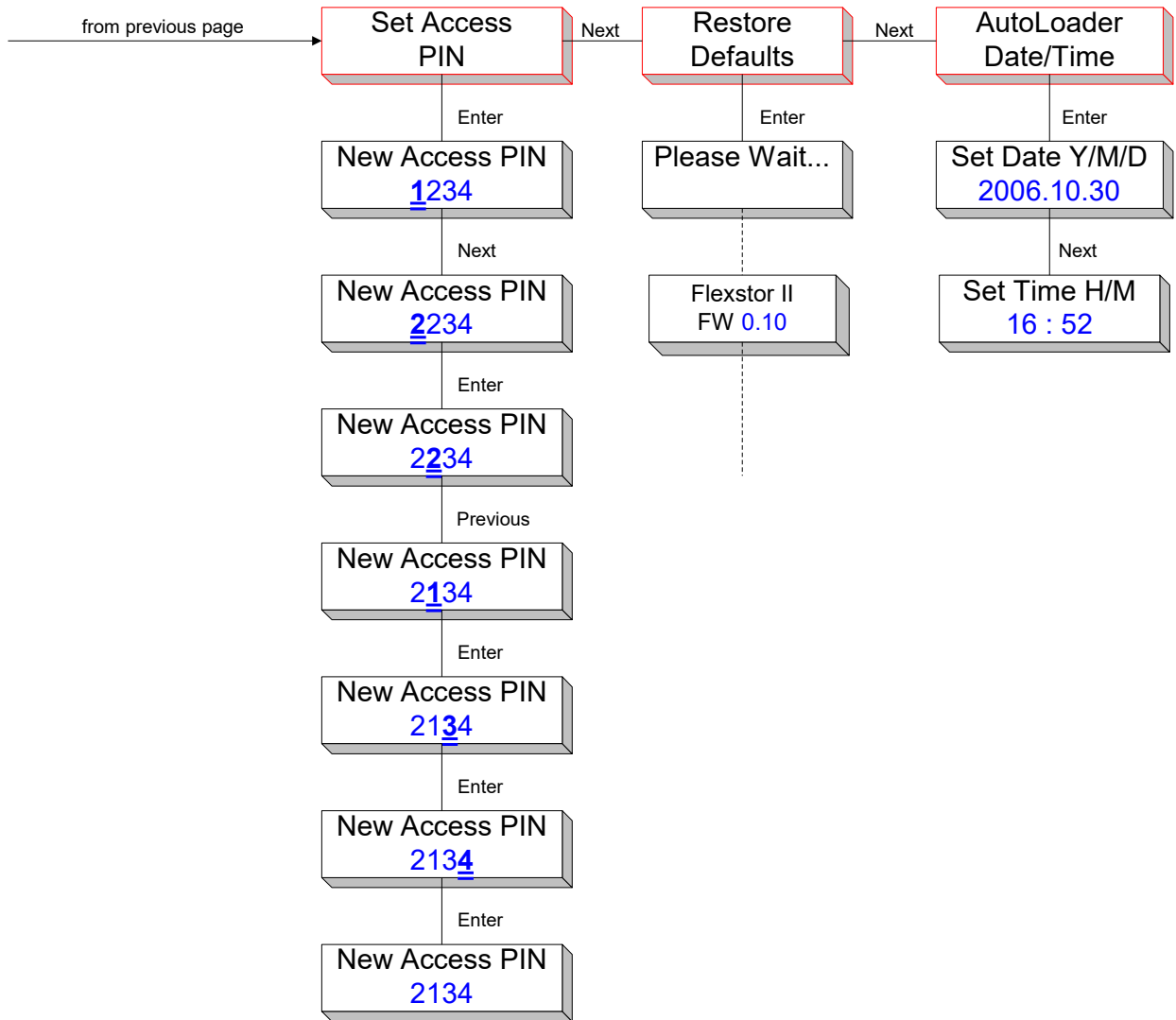

OCP LTO Drive Configuration Menu

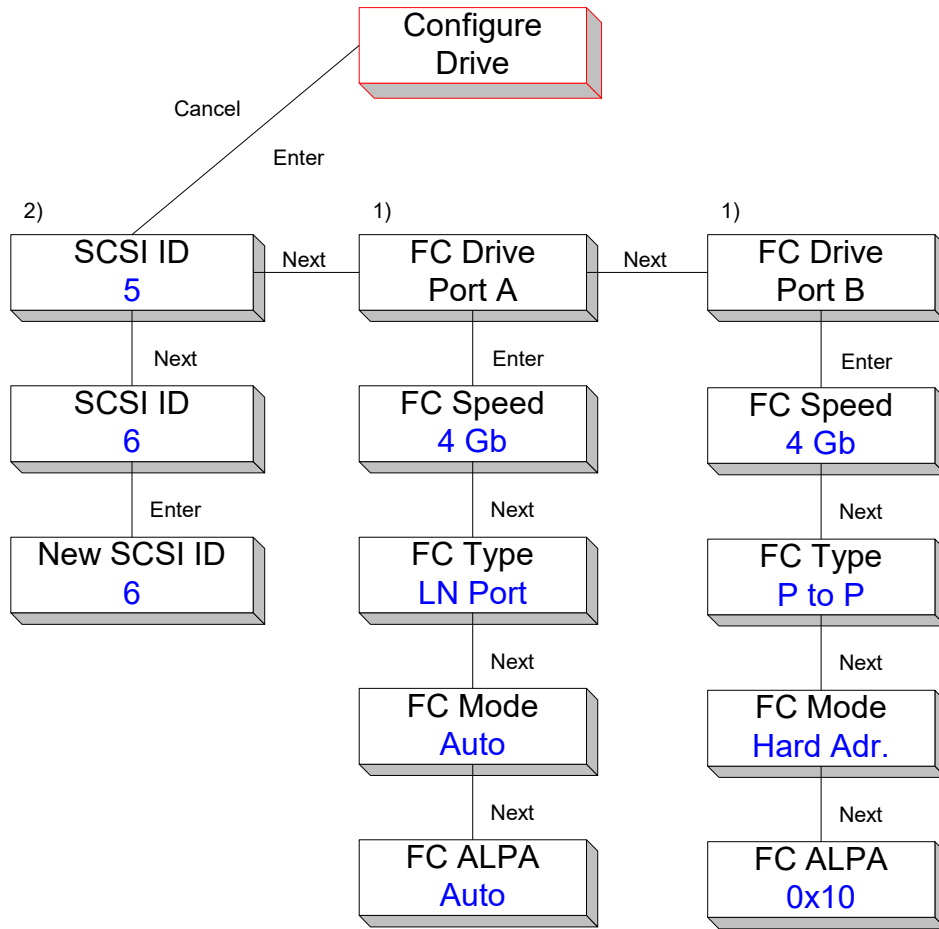

- 1) menu entry is only displayed if a fiber channel drive was found
- 2) menu entry is only displayed if a SCSI drive was found

OCP Autoloader Service Menu

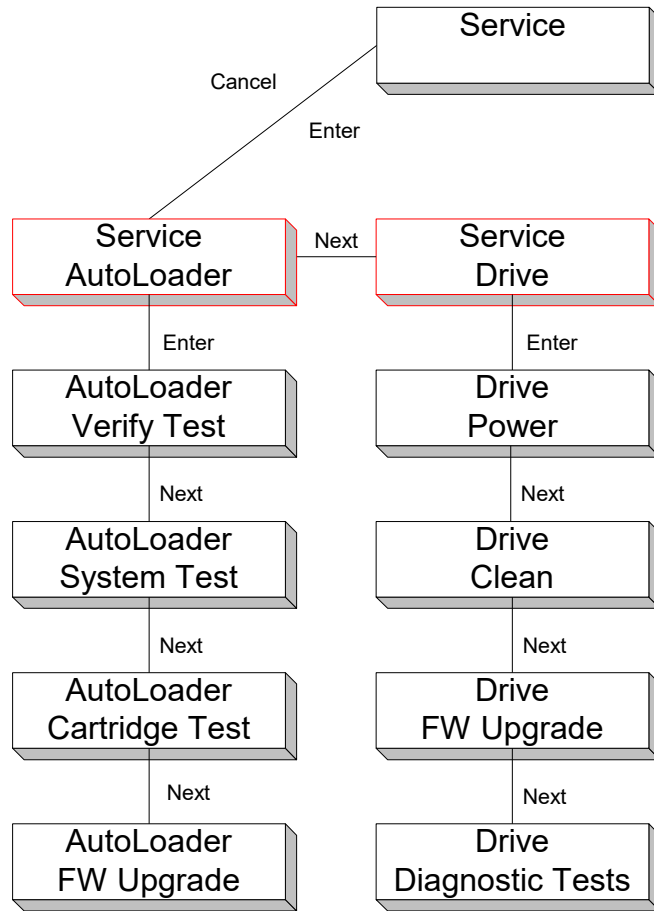

OCP Autoloader Service Menu

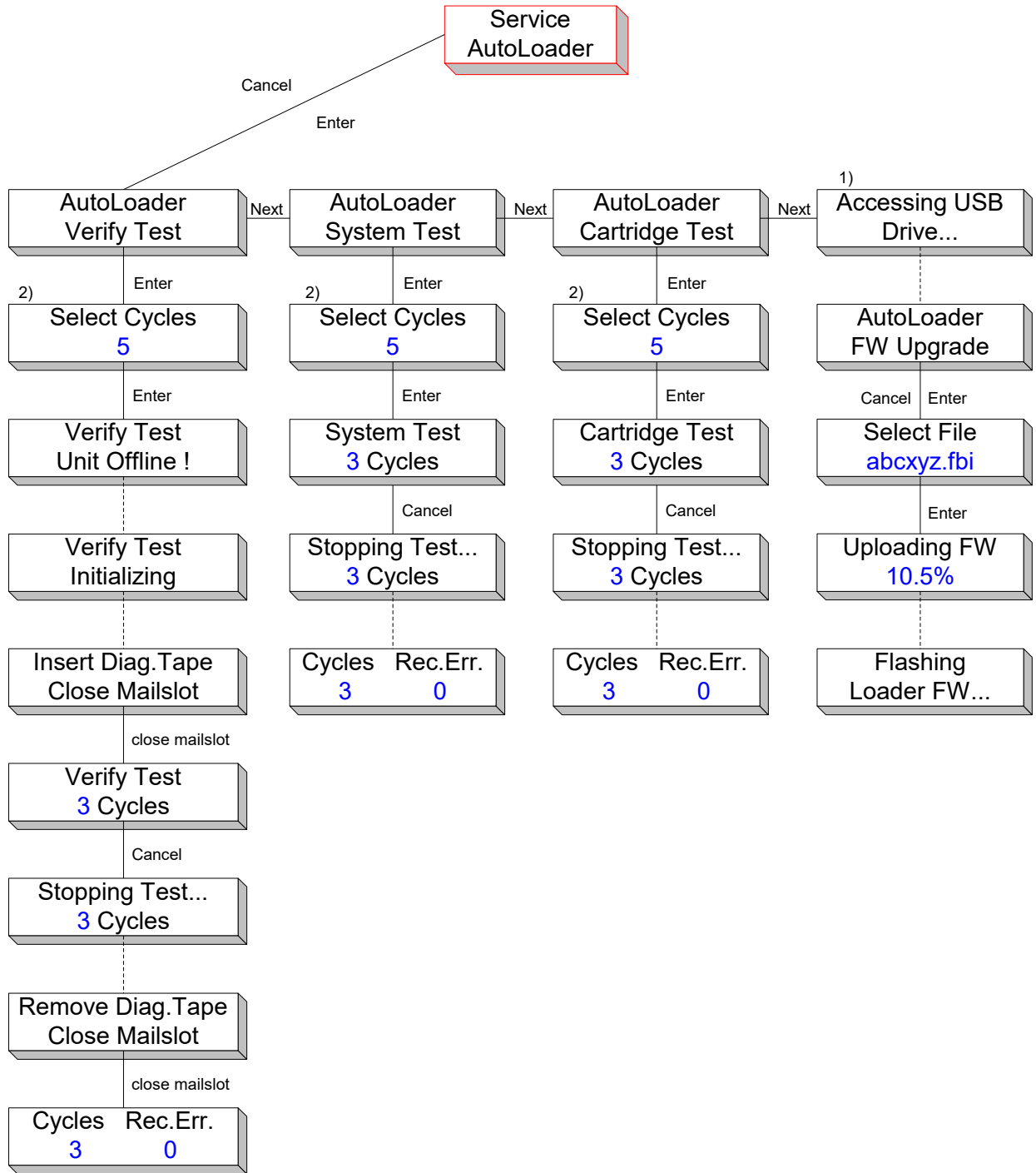

1) menu entry is displayed if a USB drive was found

2) use series of "Prev/Next's" for select

OCP LTO Drive Service Menu

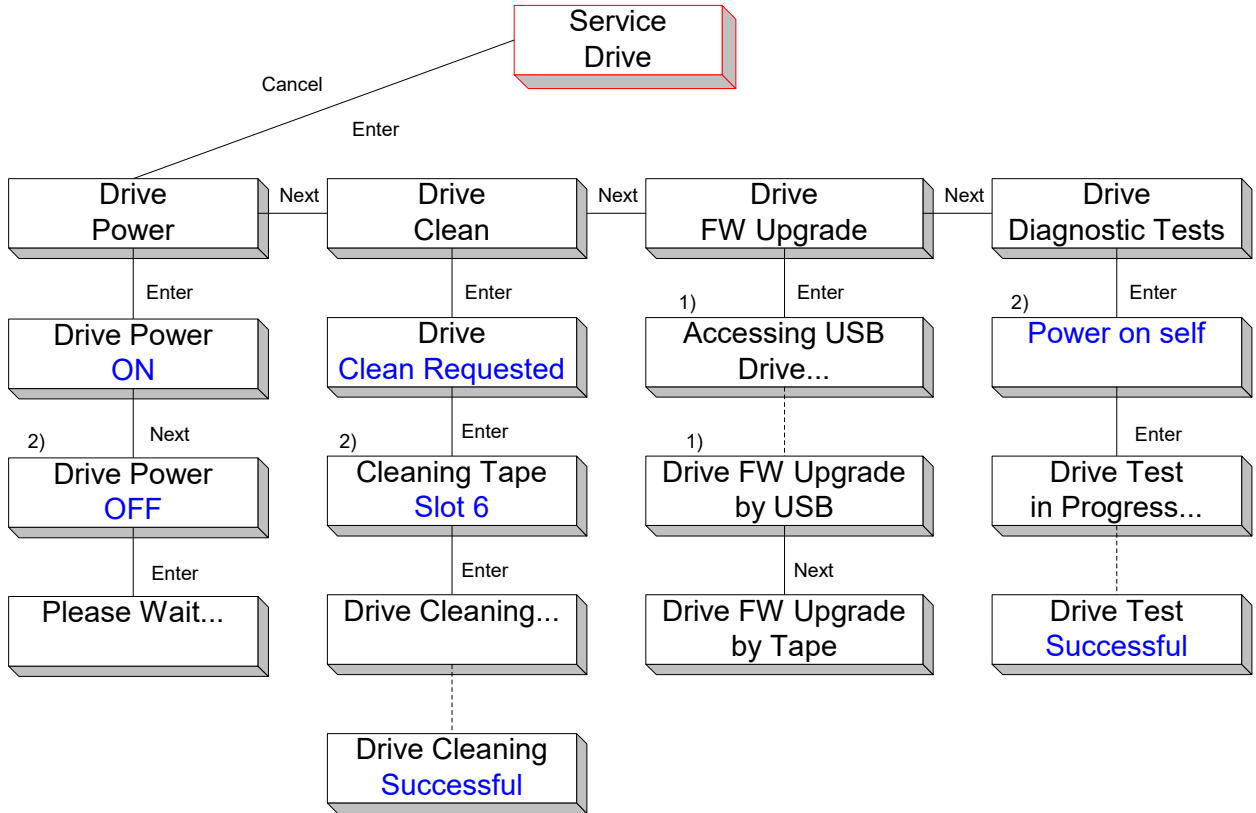

1) menu entry is only displayed if a USB drive was found

2) use series of "Prev/Next's" for select

OCP LTO Drive Firmware Upgrade Menu

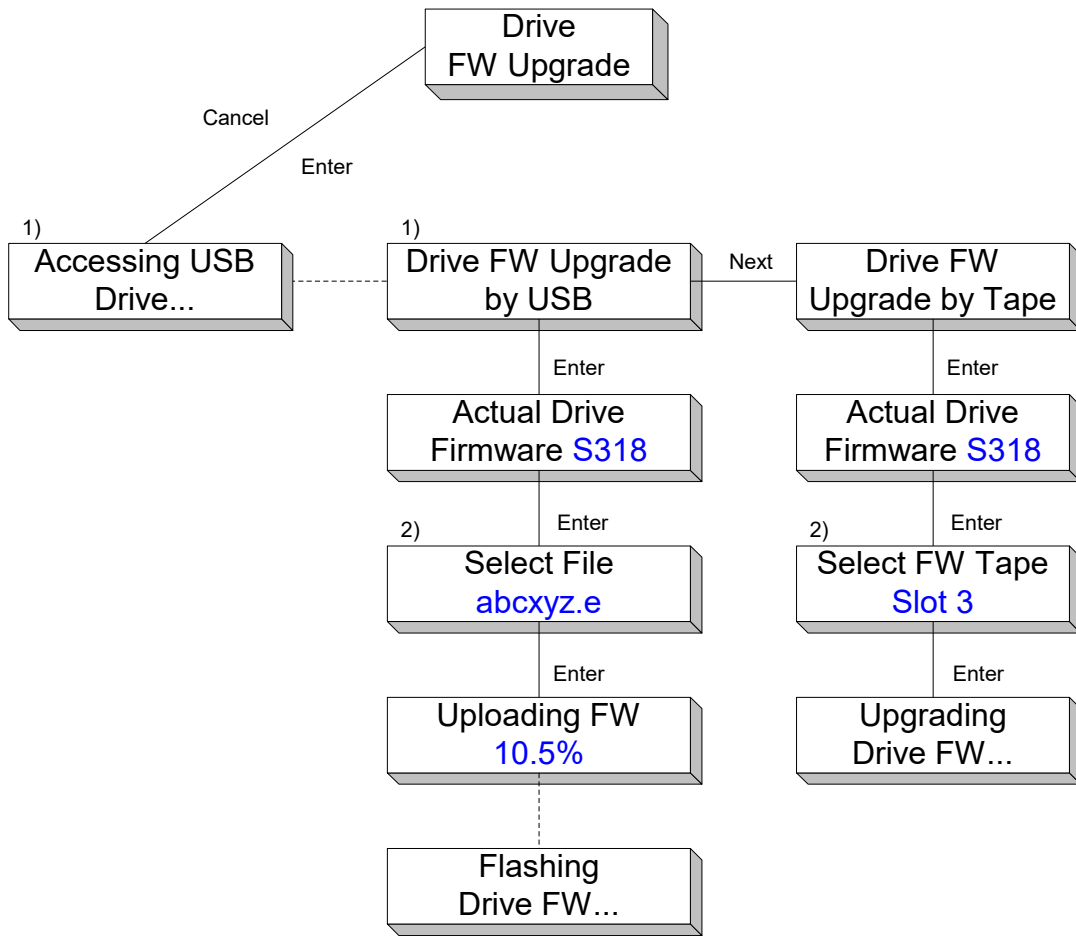

1) menu entry is only displayed if a USB drive was found

2) use series of "Prev/Next's" for select

Tape Cartridges and Magazines

This chapter explains which media to use with your library, and how to label and write-protect your tape cartridges. Careful labelling and handling of the tape cartridges will prolong the life of the tape cartridges and the library.

Using and Maintaining Tape Cartridges

Use the Ultrium data and cleaning tape cartridges designed for your model of library.

 <p>CAUTION</p>	<p>Do not degauss LTO data cartridges! These data cartridges are pre-recorded with a magnetic servo signal. This signal is required to use the cartridge with the LTO tape drive. Keep magnetically charged objects away from the cartridge.</p>
---	--

To maximise the life of your cartridges:

- **Use only approved media** for your device/model.
- **Clean the tape drive** when the **Clean Drive** LED illuminates (use an approved cleaning cartridge).
- **Handle with care**—do not drop cartridges; shock can damage the shell or internal tape media.
- **Avoid heat and sunlight.** Keep cartridges away from heaters, ducts, and direct sun.
- **Observe environmental limits.** Operating: **10–35 °C (50–95 °F)**. Storage: **–40 to +60 °C (–40 to +140 °F)** in a dust-free, **20–80% RH environment**.
- **Acclimatise after extremes.** If a cartridge has been outside these limits, let it stabilise at room temperature for the **same duration** it was exposed (or **24 hours**, whichever is less) before use.
- **Keep away from electromagnetic sources.** Do not place cartridges near strong magnetic fields or EM sources (e.g., monitors, motors, speakers, X-ray equipment), which can destroy data and servo patterns.
- **Label correctly.** Apply identification labels **only** in the designated area.

Labeling Tape Cartridges

The device contains a barcode reader that reads the tape labels and stores the inventory data in memory. The device then provides the inventory information to the host application, OCP, and RMI. Having a barcode label on each tape cartridge enables the barcode reader to identify the cartridge quickly, thereby speeding up inventory time. It is highly recommended to use barcode labels on your tape cartridges.

A correct barcode label includes the media ID in the last two characters of the barcode. The library will not load an incompatible cartridge, based on the barcode media ID, into a tape drive. For example, the library will not load a cartridge labelled as LTO-7 into an LTO-9 tape drive. This saves the time needed to load the cartridge and have the tape drive reject it.

Your host software may need to keep track of the following information via the associated bar code:

- Date of format or initialization
- Tape's media pool
- Data residing on the tape
- Age of the backup
- Errors encountered while using the tape (to determine if the tape is faulty)

! IMPORTANT	Misusing and misunderstanding barcode technology can result in backup and restore failures. Use only high-quality labels. Self-printed labels are not recommended as they are often a source of barcode reading issues.
---------------------------	---

LTO tape cartridges have a recessed area located on the face of the cartridge next to the write-protect switch. Use this area for attaching the adhesive-backed bar code label. Only apply labels as shown:

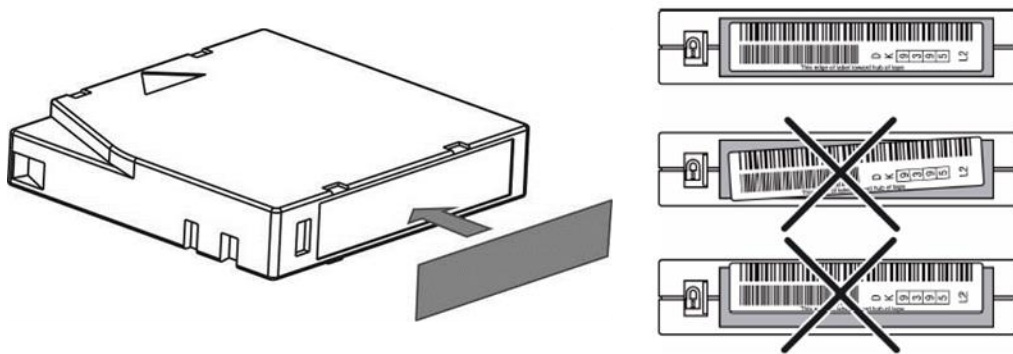

! IMPORTANT	<ul style="list-style-type: none">• The barcode label should only be applied as shown, with the alphanumeric portion facing the hub side of the tape cartridge.• Never apply any label, anywhere else on the tape cartridge. This will cause the cartridge to jam in a tape drive.• Never apply multiple labels onto a cartridge because extra labels can cause the cartridge to jam in a tape drive.
---------------------------	---

Write Protecting Tape Cartridges

All rewriteable data cartridges have a write-protect switch to prevent accidental erasure or overwriting of data. Before loading a cartridge into the device, make sure the write-protect switch on the front of the cartridge is in the desired position.

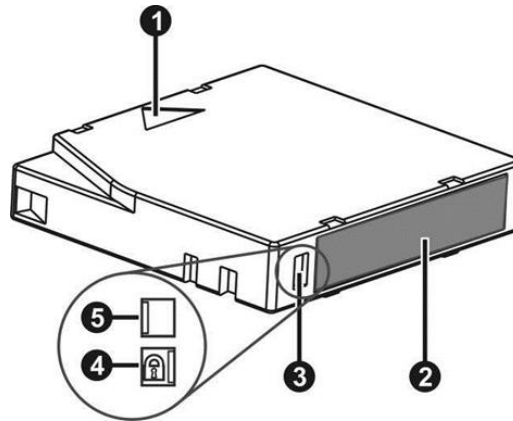

Number	Description
1	Insertion Arrow
2	Barcode Label Area
3	Write-Protection Switch
4	Write-Protected
5	Write-Enabled



NOTE

Some tape drives include support for both rewriteable and WORM data cartridges. Write-Once, Read-Many (WORM) data cartridges provide an enhanced level of data security against accidental or malicious alteration of data on the tape cartridge. The WORM data cartridge can be appended to maximize the full capacity of the tape cartridge, but the user will be unable to erase or overwrite data on the cartridge.

Read and Write Compatibility

Ultrium Read/Write Compatibility:

Number	LTO-7 Drive	LTO-8 Drive	LTO-9 Drive	LTO-10 Drive
LTO-5 Media	Read Only	Incompatible	Incompatible	Incompatible
LTO-6 Media	Read & Write	Incompatible	Incompatible	Incompatible
LTO-7 Media	Read & Write	Read & Write	Incompatible	Incompatible
LTO-8 Media	Incompatible	Read & Write	Read & Write	Incompatible
LTO-9 Media	Incompatible	Incompatible	Read & Write	Incompatible
LTO-10 Media	Incompatible	Incompatible	Incompatible	Read & Write

Barcode Reader

The barcode reader provides inventory feedback to the host application and/or LCD screen by reading the cartridge barcode labels. The autoloader stores the customized inventory data in memory.

Magazines

Cartridges are stored in magazines. Up to 4 cartridges can be stored in each magazine. Magazines may be removed and inserted individually.

The SymplyPRO XTL 8 has two removable magazines. Magazine access can be password protected. For safety reasons, the robotic motion is stopped when a magazine is removed. The magazines can be released using the Operator Control Panel (OCP) or the Remote Management Unit (RMU). In case the OCP or RMU initiated process has failed or the autoloader no longer has power a manual emergency release is available.

! IMPORTANT	To manually release a magazine, see “Magazine emergency release.” However, this manual process should only be used if the magazine cannot be released using the Operator Control Panel or the Remote Management Unit.
---------------------------	---

Inserting tape cartridges into a magazine

- 1) Unlock the magazines and remove it from the autoloader.
 - a. Use the OCP.
 - b. Use the RMU.
- 2) Insert cartridge in the magazines.
- 3) Put the full magazines back to the tape autoloader.

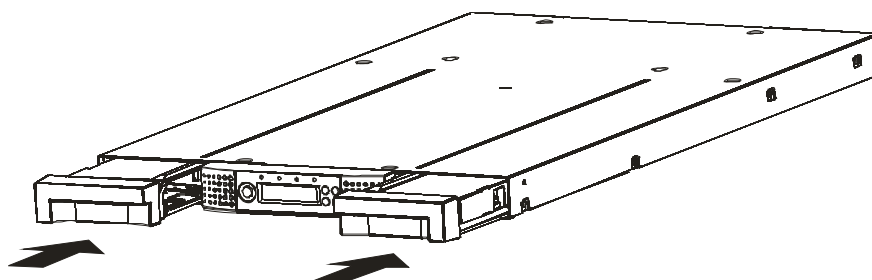

Removing and replacing a magazine using the OCP

The magazines should be released using the Operator Control Panel (OCP) or the Remote Management Unit (RMU). It is recommended you release the magazine using the OCP or RMU, however, if the OCP process fails, or if the magazine needs to be removed when the power to the tape autoloader is off, you can manually release the magazines.

This OCP option lets you gain access to the left and right magazine. Access to the magazines may require the use of the administrative password.



IMPORTANT

The magazine must only be removed manually in an emergency. Failure to follow normal procedure can cause data loss and equipment damage.

To remove a magazine using the OCP:

- 1) From the Home screen, press “Up” or “Down” on the OCP until the screen displays Operations.
- 2) Press “Enter” to select.
- 3) Press “Up” or “Down” until the screen displays either Unlock Left Magazine, or Unlock Right Magazine.
- 4) Press “Enter” to select the desired magazine to unlock.
- 5) “Enter” the Administrative password if requested.
- 6) The display will read Left Magazine Unlocked, or Right Magazine Unlocked.
- 7) Pull the released magazine out of the autoloader.
- 8) The screen will now display Insert Left Magazine, or Insert Right Magazine. The autoloader cannot perform any other operation until the magazine is replaced. After exchanging tapes in a magazine, slide the magazine completely into the autoloader. The magazine will lock into place once it is correctly installed, and the autoloader will inventory the magazine.

Removing and replacing a magazine using the RMU

- 1) To login, enter the correct password, and press Enter.
- 2) Go to Operations > Magazines.
This page allows the user to release the right or left magazine from the autoloader.
- 3) Press the Release button.
- 4) Remove the magazine from the unit.

Slot numbering – Left Magazine

The slot numbering scheme is shown below for the left magazine for the left magazine.

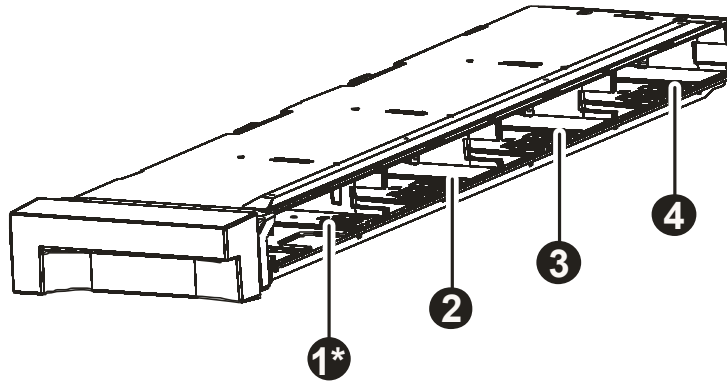

Number	Description
1	Mailslot
2	LTO Slot
3	LTO Slot
4	LTO Slot

Slot numbering – Right Magazine

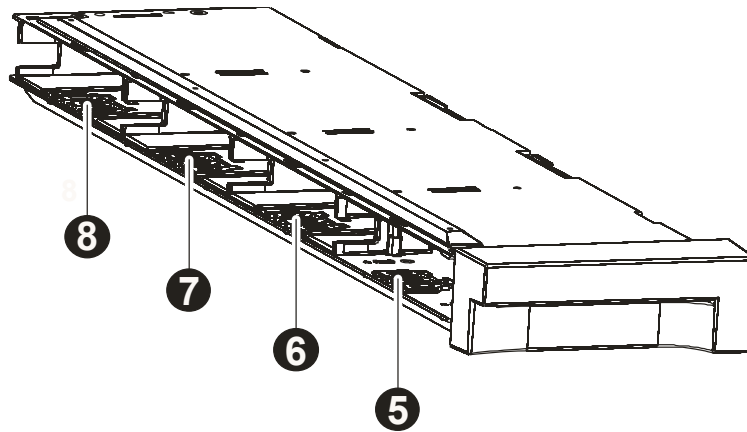

Number	Description
5	LTO Slot
6	LTO Slot
7	LTO Slot
8	LTO Slot

Mailslot

Mail slots are used to import/export individual cartridges without interrupting autoloader operation. The command to open the mail slot may be denied if the robotics is busy with some operation.

In that case “Busy” is displayed and the command has to be repeated once the robotics operation is finished.

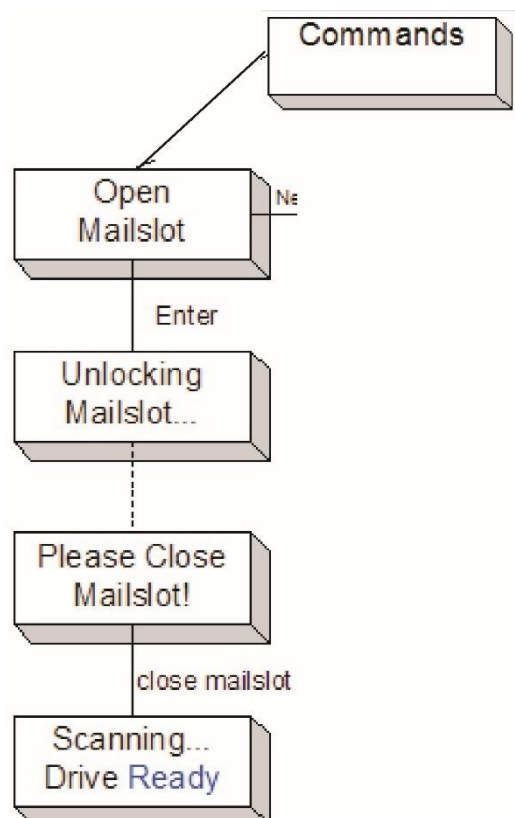

Remote management unit (RMU)

Many of the same operations performed from the operator control panel can also be performed remotely using the Remote Management Interface.

The RMU lets you monitor and control your autoloader from any terminal connected to your network or through the World Wide Web (WWW). The RMU hosts a dedicated, protected Internet site that displays a graphical representation of your autoloader.

After establishing a connection to the autoloader, open any HTML browser and enter the IP address of the autoloader. To configure the RMU, you must set the IP address at OCP or DHCP.

Operations available through the RMU include:

Identity:

- Viewing static autoloader information
- Viewing static drive information

Status:

- Viewing dynamic autoloader information
- Viewing dynamic drive information
- Viewing the tape cartridge inventory
- Configuration
- Changing the system configuration
- Changing the drive configuration
- Changing the network configuration
- Changing the administrative password
- Setting date/time
- Setting error log mode
- Setting event notification parameters
- Restoring factory defaults

Operations:



- Moving media within the autoloader
- Determining current media inventory
- Releasing and replacing magazines

Service:

- Performing general autoloader diagnostics
- Determining and updating firmware
- Rebooting the autoloader
- Viewing autoloader logs
- Cleaning tape drive(s)

RMU Autoloader Status Icons

Status icons indicate the following conditions:

Icon	Description
	The green Status Ok icon indicates that the autoloader is fully operational and that no user intervention is required.
	The yellow exclamation point for Status Warning indicates that user intervention is necessary, but that the autoloader is still capable of performing operations.
	The red X Status Error indicates that user intervention is required and that the autoloader is not capable of performing operations.

RMU Login

To login, select the access type and enter the correct password. There are three levels of access:

- Standard user level.
- Admin user level.
- Service personnel user level. Access to this level is by Service personnel only.

Each level affects which areas you have access to and what actions you can initiate from those areas.

<p>!</p>	<p>IMPORTANT</p>	<p>Some options of the RMU take the autoloader offline. This inactive mode can interfere with host-based application software, causing data loss. Make sure the autoloader is idle before attempting to perform any remote operations that will take the autoloader offline.</p>
-----------------	-------------------------	--

RMU Login Page:

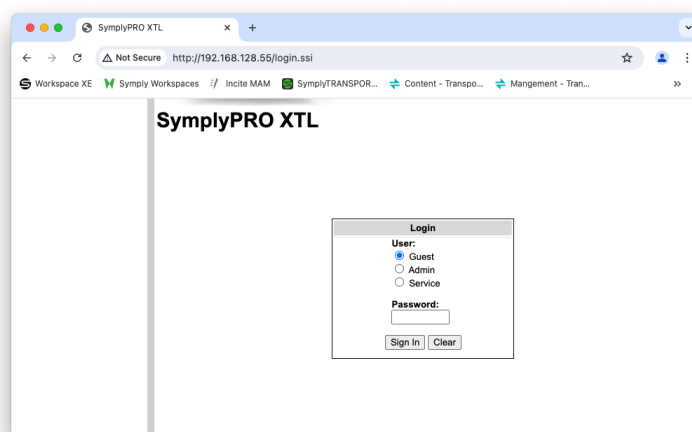

RMU Autoloader Information

Viewing Autoloader Information

This page provides access to the static information about the system. The following information can be found, although no changes can be made from this page:

- Serial Number
- Product ID
- Currently Installed Firmware
- Bootcode Firmware Revision
- IP Address
- Library Mode

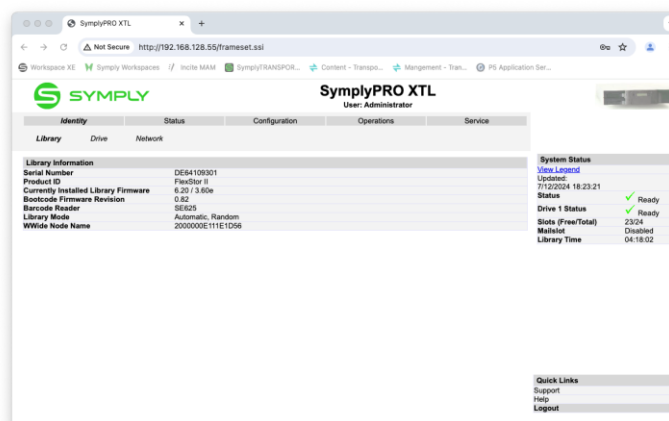

Viewing static drive information

This page provides detailed information about the drive. No changes can be made from this page.

The screenshot shows the SymplyPRO XTL interface with the user logged in as Administrator. The main navigation tabs are Identity, Status, Configuration, Operations, and Service. Below these are sub-tabs for Library, Drive, and Inventory. The 'Drive' sub-tab is active, displaying 'Drive 1 Status At 04:24:42 Library Time'. The status table shows 'Status' as 'Ready' with a green checkmark, 'Cartridge In Drive' as 'None', 'Drive Error Code' as 'No Error', and 'Cooling Fan Active' as 'Ready' with a green checkmark. Other metrics include 'Drive Activity' (Ready), 'Port A Status' (Ready, connected), 'Speed' (6 Gb/sec), 'Hashed SAS address' (9E7704), 'Port B Status' (Not ready, not connected), and 'Hashed SAS address' (-). A 'Refresh' button is located below the table. On the right, the 'System Status' panel shows 'Status' as 'Ready' with a green checkmark, 'Drive 1 Status' as 'Ready' with a green checkmark, 'Slots (Free/Total)' as '23/24', 'Mailslot' as 'Disabled', and 'Library Time' as '04:24:41'.

RMU Autoloader Status

This page displays the dynamic information about the autoloader, such as the current status of the components. The following information can be found on this page:

- Status
- Cartridge in Operation
- Odometer
- Total Power On Time
- Robotic Status
- Magazine Left
- Magazine Right
- Mailslot

The screenshot shows the SymplyPRO XTL interface with the user logged in as Administrator. The main navigation tabs are Identity, Status, Configuration, Operations, and Service. Below these are sub-tabs for Library, Drive, and Inventory. The 'Library' sub-tab is active, displaying 'Library Status At 04:23:09 Library Time'. The status table shows 'Status' as 'Ready' with a green checkmark, 'Cartridge In Transport' as 'None', 'Number Of Moves' as '24', 'Total Power On Time' as '43d 11h 37min', 'Robotic Status' as 'Ready', 'Internal Temperature' as '34.1 °C', 'Left Magazine' as 'Present', and 'Right Magazine' as 'Present'. A 'Refresh' button is located below the table. On the right, the 'System Status' panel shows 'Status' as 'Ready' with a green checkmark, 'Drive 1 Status' as 'Ready' with a green checkmark, 'Slots (Free/Total)' as '23/24', 'Mailslot' as 'Disabled', and 'Library Time' as '04:23:09'.

View Drive Information

This page provides detailed information about the drive which is present in the autoloader.

Identity	Status	Configuration	Operations	Service
Library	Drive	Inventory		

Drive 1 Status At 04:24:42 Library Time	
Status	✓ Ready
Cartridge In Drive	None
Drive Error Code	No Error
Cooling Fan Active	✓
Drive Activity	Ready
Port A Status	Ready, connected
Speed	6 Gb/sec
Hashed SAS address	9E7704
Port B Status	Not ready, not connected
Speed	-
Hashed SAS address	000000

System Status	
View Legend	
Updated:	7/12/2024 18:30:0
Status	✓ Ready
Drive 1 Status	✓ Ready
Slots (Free/Total)	23/24
Mailslot	Disabled
Library Time	04:24:41

Viewing the tape cartridge inventory

This page provides detailed information about the tape inventory in the autoloader. A summary of each magazine is shown. To get detailed information, click on the + button. This will expand the display for the specified magazine.

Using RMU To Configure the XTL 8

Changing the system configuration

As changes are made, they will only be applied after the “Apply Selections” or the “Submit” button is selected. After making the selection, a warning page will inform the user of the impact of their proposed change. In some cases, a pop-up screen will ask the operator to confirm their change. Many changes will also require a reboot.

Changes that can be made are:

- Autoloader Mode: Random, Sequential, Automatic Autoload, Loop
- Mailslot Enabled
- Barcode Label Length Reported To Host (**typically 8** for most applications)
- Auto Clean Enabled

Identity	Status	Configuration	Operations	Service
System	Logical Libraries	Drive	Network	SNMP
		User	Date/Time	Log
			Email Notification	Restore Defaults

System Configuration	
Library Master Drive	1
Library Mode	<input type="radio"/> Random <input type="radio"/> Sequential <input checked="" type="radio"/> Automatic
	<input type="checkbox"/> Autoload <input type="checkbox"/> Loop
Active Slots	24
Telnet Enabled	<input type="checkbox"/>
Mailslot Enabled	<input type="checkbox"/>
Auto Clean Enabled	<input type="checkbox"/>
Barcode Label Length Reported To Host	15
Barcode Label Alignment Reported To Host	Left
Select Language	English
Enable Extended Mode	<input type="checkbox"/>

System Status	
View Legend	
Updated:	7/12/2024 21:1:6
Status	✓ Ready
Drive 1 Status	✓ Ready
Slots (Free/Total)	23/24
Mailslot	Disabled
Library Time	06:55:47

Changing the drive configuration

This page shows the current configuration of the drive in the autoloader and allows modification to the configuration. The user is also able to select Power on through this page while activates the drive.

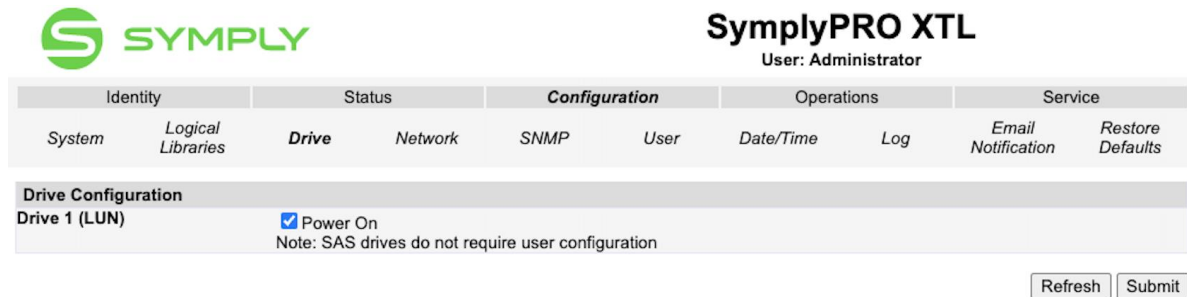

Changing the network configuration

This page shows the current network configuration of the autoloader and allows modification to the configuration. When a change is requested, a pop-up box will ask to confirm the changes.

A list of changes that can be made are:

- DHCP Address - checked On or unchecked Off (when on static address not used)
- IP Address
- Network Mask
- Gateway Address

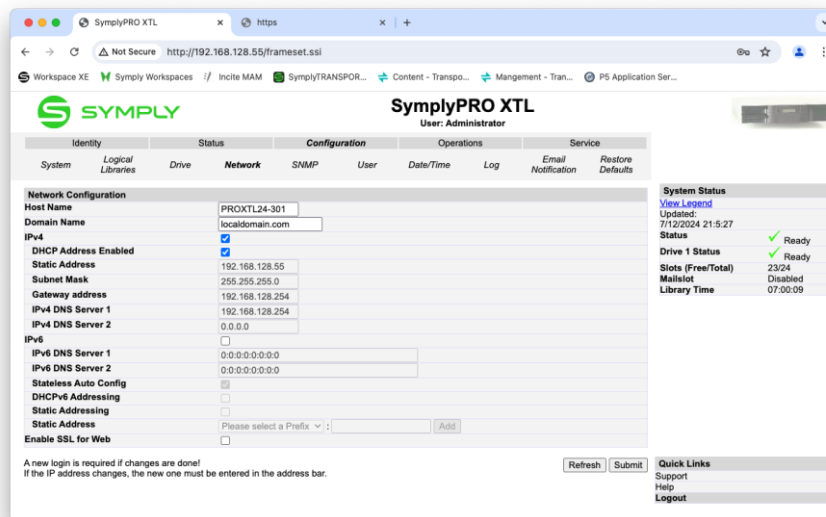

Changing the usernames and password

This page allows the user to add and modify user accounts.

- Access Level - Choose from 1 (Standard), 2 (Admin), or 3 (Service).
- Access Level Name – the name associated with the chosen Access Level
- New Password – The password can be a maximum of ten characters.
- Repeat Password – Enter the new password again.
- OCP Access PIN Enabled – Select this item, if you would like the Operator Control Panel to display to be password protected.
- OCP Access PIN Code – the password for accessing the OCP when the OCP Access PIN is enabled.
- Repeat OCP Access PIN Code – Enter the OCP Access PIN Code again.
- Support Name – the name of the individual within your company to contact for RMU or autoloader support.
- Support Phone – the phone number of the individual within your company to contact for RMU or autoloader support.
- Support Email – the email address of the individual within your company to contact for RMU or autoloader support.

Setting date/time

This page allows the user to set the time and date, and how it will be displayed.

SymplyPRO XTL
User: Administrator

Identity		Status		Configuration		Operations		Service	
System	Logical Libraries	Drive	Network	SNMP	User	Date/Time	Log	Email Notification	Restore Defaults

Clock Configuration

Time (24H) [07]:[05]:[16]

Date Month: [02] Day: [21] Year: [2000]

Clock Synchronization Configuration (SNTP)

Enable Clock Synchronization

SNTP Server Address (IPv4) [] IPv4 address or Host name and domain *

UTC Time Zone Offset [(GMT) Casablanca, Monrovia, Greenwich Mean Time: Dublin,Edinburgh,Lisbon,London]

Daylight Saving Enabled

* If a host and domain name are entered instead of an address, the IPv4 or IPv6 address will be resolved from the DNS using that name. That address will be stored in the library rather than the name. Therefore, if the address changes, then the name or a new address will have to be entered.

[Refresh] [Submit]

Setting error log mode

This page allows the user to set the error log mode to Off, Continuous, or to Stop trace at first error.



NOTE

The trace level and trace filter selection options are only changeable by Service personnel.

Setting event notification parameters

This page allows the user to set event notification to On. The Choices for event notification are:

- Notify Errors – Select this item to be notified of autoloader errors via email.
- Notify Warnings – Select this item to be warnings of autoloader errors via email.
- To E-mail Address – Enter the email address of the individual you would like to receive the errors and/or warnings.
- E-mail Domain – Enter the email domain name of the individual you would like to receive the errors and/or warnings.
- SMTP Server Address - Enter the address of thee mail server of the individual you would like to receive the errors and/or warnings.

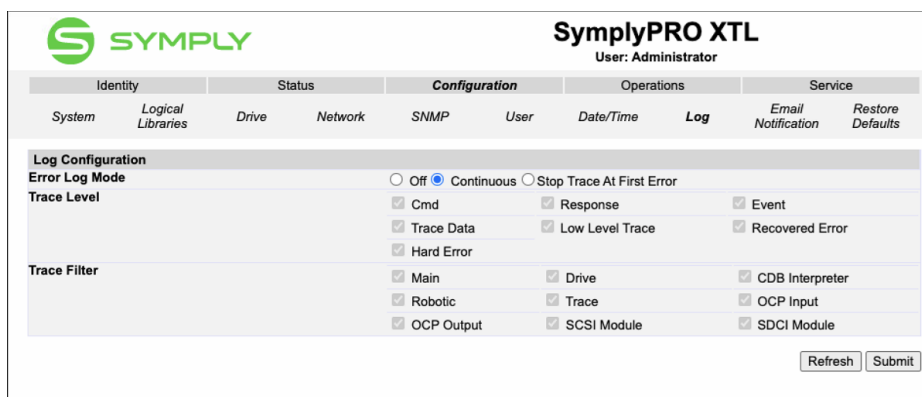

Restoring factory defaults

This page allows the user to reset the configuration to the factory defaults, restore vital product data, and save vital product data.

RMU Operations

Moving media within the autoloader

This page allows the user to move tape cartridges within the autoloader. The source and destination are selected and then the move button in the centre of the screen is clicked to activate the move.

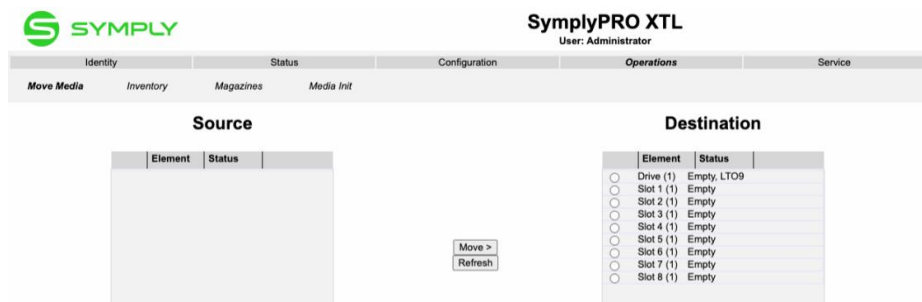

Determining current media inventory

This page provides the user with a means to re-scan the autoloader to determine the current media inventory.

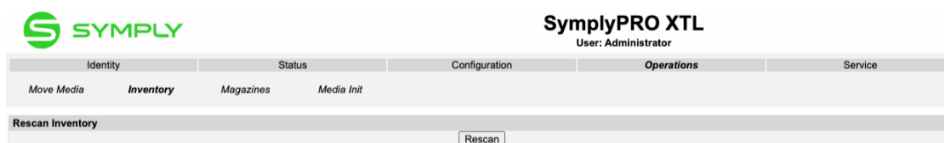

Releasing and replacing magazines

This page allows the user to release the right or left magazine from the autoloader.



NOTE

A magazine can be manually released. However, this manual process should only be used if the magazine cannot be released using the Operator Control Panel or the Remote Management Unit.

Media Initialization

Every LTO-9 media must be optimized, sometimes referred to as characterised or initialised before the first use. See LTO-9 media Optimization page 18.

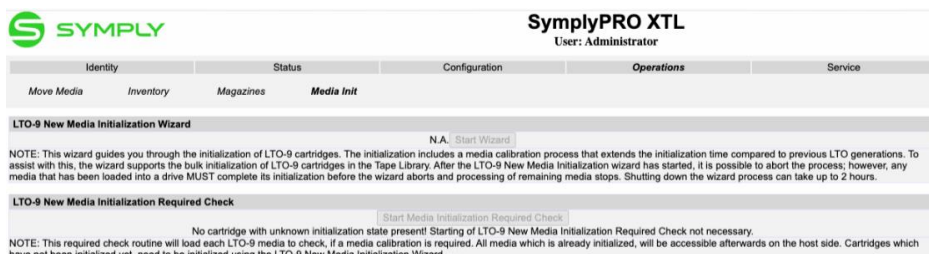

The XTL 8 offer a wizard that initializes the LTO media. Select **Operations >> Media Init. >> Start Assistant** in the menu.

Inserting an uninitialized LTO-9 medium will automatically initialize it.

RMU Servicing

Some options of the RMU take the autoloader offline. This inactive mode can interfere with host-based application software, causing data loss. Ensure that the autoloader is idle before attempting to perform any remote operations that will take the autoloader offline.

Performing general autoloader diagnostics

This page provides the system administrator with general tests to verify the usability and reliability of the autoloader. The user selects the number of test cycles before starting the test. To cancel the test before it completes the cycles, select the Stop button.

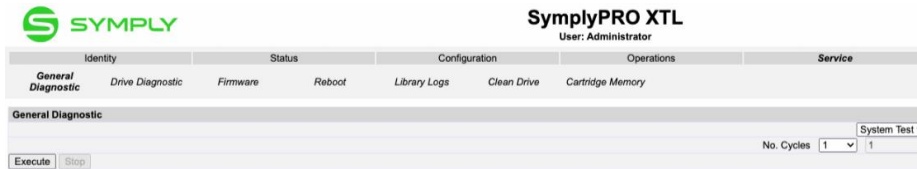

Determining and updating firmware

This page displays the current autoloader and all drive firmware versions. Firmware can be downloaded to the host then uploaded to the drive in the autoloader by using this page.

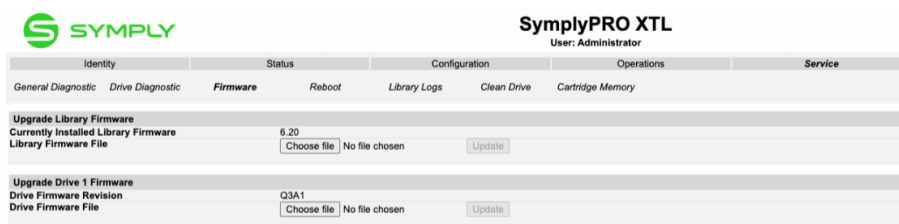

!	Important	After an autoloader upgrade the system restarts automatically. Make the autoloader is not in user and any media has been unloaded for the LTO drives.
----------	------------------	---

Rebooting the autoloader

This page is used to perform an autoloader reboot. There is a default time delay when the Web page refreshes itself. This time should be sufficient to reload the page. However, during a reboot, the connection to the autoloader may be lost. If the connection is lost, the user will have to reload the page manually.

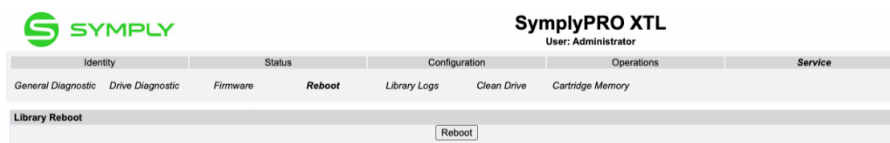

Hardware servicing of the SymplyPRO XTL 8 autoloader.

When servicing the SymplyPRO XTL 8 autoloader caution should be used whenever lifting the SymplyPRO XTL in and out of the shipping carton or rack, make sure that the working area around you is clean and free from obstructions.

To prevent electrostatic damage, when servicing the SymplyPRO XTL observe the following precautions:

- Transport products in static-safe containers such as conductive bag.
- Keep electrostatic-sensitive parts in their containers until they arrive at static-free stations.
- Cover the autoloader with approved static-dissipating material. Provide a wrist strap connected to the work surface and properly grounded tools and equipment.
- Keep the work area free of non-conducting materials, such as ordinary plastic assembly aids and foam packing.
- Make sure you are always properly grounded when touching a static-sensitive component or assembly.
- Avoid touching pins, leads, or circuitry.
- Use conductive field service tools.

 CAUTION	A discharge of static electricity can damage static-sensitive devices or micro circuitry. Proper packaging and grounding techniques are necessary precautions to prevent damage.
--	--

Tools that might be needed for servicing.

To service the SymplyPRO XTL 8 autoloader you may need one or more of the following tools:

- Flat-blade screwdrivers (large and small)
- #3 Phillips screwdriver
- Cross-slot screwdriver
- Ground strap

Removing and replacing a tape drive.

Tape drive is installed at the back of the autoloader.

To remove the tape drive:

- 1) Using your Remote Management Unit, the Operator Control Panel, or the data protection application on the host, unload the tape cartridge(s) from the drive to be removed.

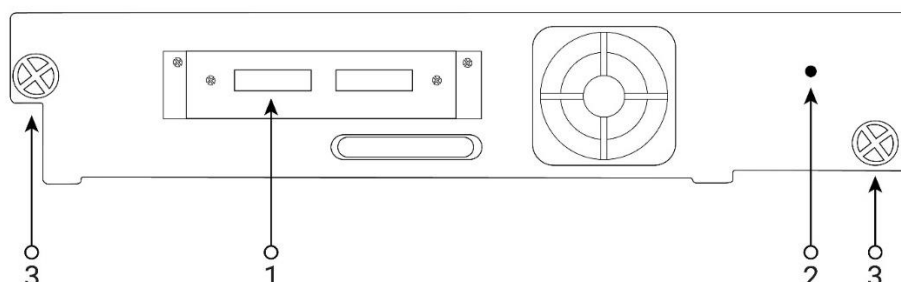

Number	Description
1	Data Cable Connection (Port A)
2	Drive Power Light
3	Captive Thumbscrews

- 2) Power down the autoloader using the power button on the front panel.
- 3) Make sure the LED on the tape drive is off.
- 4) Remove the data cable (SAS or Fibre Channel) from the tape drive.
- 5) Loosen the captive thumbscrews on the drive.
- 6) Pull straight back on the tape drive handle to remove it from the autoloader. Take care to slightly push down the product ID tag so it does not interfere with the drive sled.

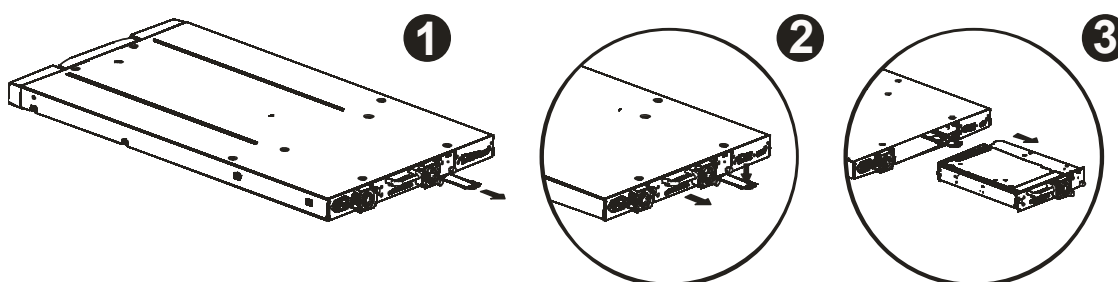

IMPORTANT

Before pulling the lower drive sled, please pull forward the product ID tag located below the drive sled. Otherwise, the slide or the attached label could be damaged.

To replace a tape drive:

- 1) Before installing the new drive inspect the connectors on the tape drive. Ensure that the connectors are intact, free of any foreign objects, and have no cracks or deformed or bent contacts.
- 2) Slowly insert the new tape drive into the drive bay and align the connectors on the autoloader while supporting the drive assembly.
- 3) Push the Product ID tag slide down slightly to prevent damage.

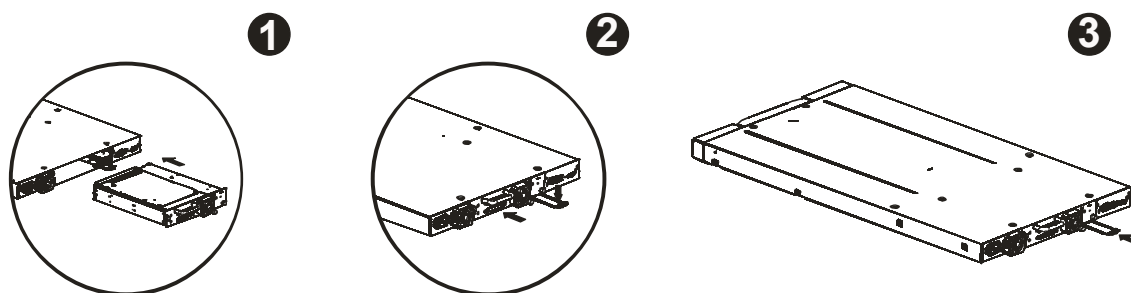

- 4) Push the tape drive slowly into the drive bay until the drive seats itself against the back of the autoloader.
- 5) Push the Product ID tag slide back underneath the drive sled. When inserted properly, only the handle of the slide will be visible.
- 6) Tighten the captive thumbscrews until the drive is secure.
- 7) Connecting the power cable, and SAS or Fibre Channel cable.
- 8) Power on the autoloader using the power button on the front panel.
- 9) Run the Autoloader Verify test.

Removing and replacing the power supply.

Removing the power supply.

Power supply is installed at the back of the autoloader. Before you remove the power supply:

- 1) Turn off power to the autoloader (power button on the front panel).
- 2) Remove the power cord cable.
- 3) Loosen the three captive thumbscrews on the power supply.
- 4) Pull straight back on the power supply to remove it from the autoloader.

Replacing the power supply

- 1) Unpack the new power supply from its package.
- 2) Slowly insert the new power supply into the bay and align the connectors on the autoloader while supporting the power supply assembly.
- 3) Tighten the captive thumbscrews until the power supply is secure.
- 4) Replace the power cord cable.
- 5) Switch on power to the autoloader (power button on the front panel).

Removing and replacing the autoloader controller.

The autoloader controller maintains a backup of all Critical and Configuration Data separate from the autoloader controller, so that when replacing the autoloader controller, the Critical and Configuration data can be maintained and will not have to be entered manually again.

When replacing an autoloader controller, or a chassis FRU, there will be a mismatch between the data on the autoloader controller and the backup data. When such a mismatch is detected, the user will be requested to determine which set of data is correct. If the autoloader controller has been replaced, then select “Identity data mismatch” to copy the backup data onto the autoloader controller. If the chassis FRU or Robotics FRU has been replaced (maintaining the original autoloader controller), then select “Replace backup data”.

To remove the autoloader controller

Autoloader controller is installed at the back of the autoloader. Before you remove the autoloader controller:

- 1) Turn off power to the autoloader (power button on the front panel).
- 2) Remove the power cord cable.
- 3) Loosen the two captive thumbscrews on the autoloader controller.

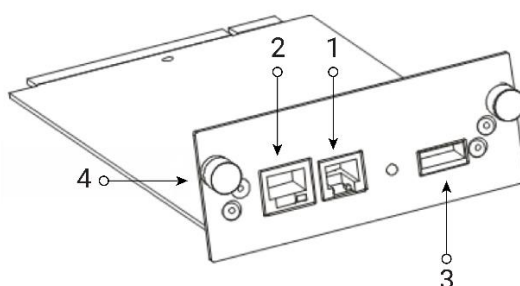

Number	Description
1	Ethernet Management Port
2	Service Port
3	USB Port
4	Captive Thumb Screws

- 4) Carefully pull out the controller module.
- 5) Place the removed controller module in a suitable anti-static bag.

Replacing the autoloader controller

- 1) Unpack the new autoloader controller from its package.
- 2) Slowly insert the new autoloader controller into the bay and align the connectors on the autoloader while supporting the controller assembly.
- 3) Tighten the captive thumbscrews until the autoloader controller is secure.
- 4) Replace the power cord cable.
- 5) Switch on power to the autoloader (power button on the front panel).

Removing and replacing the base chassis

In rare cases Symply may need to replace the SymplyPRO XTL 8 base chassis, and a replacement will be shipped to you.

You will need a #3 Phillips screwdriver to remove and replace the base chassis assembly.

 <p>WARNING</p> <p>59 - 66 lbs 26 - 29 kg</p>	<p>The SymplyPRO XTL 8 weighs 11.4 Kg with the drive, 13.1 Kg with media.</p> <p>Risk of personal injury or damage to the autoloader due to the weight! Always remove all tapes to reduce the overall weight of the autoloader. Always observe local health and safety requirements and guidelines for manual material handling.</p>
---	--

To remove the components in the base chassis and the base chassis from the rack:

- 1) Observe local health and safety requirements and guidelines for manual material handling.
- 2) Obtain adequate assistance to lift and stabilize the autoloader during removal and replacement.
- 3) Remove the magazines from the autoloader.
- 4) Turn off power to the autoloader and disconnect all cables.
- 5) From the front of the autoloader loosen the two screws anchoring the mounting brackets on the autoloader to the rack. These are captive screws and cannot be removed.
- 6) Remove your autoloader from the rack and place on a solid surface in preparation for re-packing the autoloader.
- 7) Remove the replacement autoloader enclosure from the packing materials.
- 8) Place the replacement autoloader enclosure on a solid surface in preparation for installation into the rack.
- 9) Remove the mounting brackets and guide pulleys from your autoloader and install them on the replacement autoloader.
- 10) Loosen the blue thumbscrews on the tape drive and pull the tape drive handle while supporting the bottom of the drive to remove from your autoloader.
- 11) Install your drive in the replacement autoloader enclosure.
- 12) Remove the shipping lock on the rear panel.
- 13) Store the lock and label to the top cover.

- 14) Slide the replacement autoloader enclosure onto the metal rails that are already in position in the rack.
- 15) Tighten the mounting bracket screws to anchor the replacement autoloader enclosure to the rack.
- 16) Plug in the power cord and host interface cable into the replacement autoloader enclosure.
- 17) Power on the autoloader.
- 18) Run the Autoloader Verify test (refer to OCP “Service: Autoloader Verify”).
- 19) Securely package the autoloader enclosure that was replaced and return to Symply.

Packaging the SymplyPRO XTL before transportation

- 1) Please disconnect the autoloader, power, and data cables
- 2) Remove the yellow label and the shipping lock. The shipping lock is store on the rear panel.
- 3) Store the lock and the label on the top cover. The shipping lock which prevents the robotic mechanism from moving during shipment

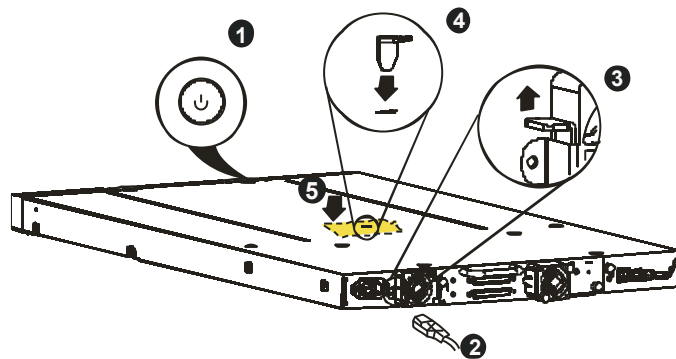

- 4) Packaging the tape autoloader. Please use this reason original shipping carton. Failure to do so could result in in the warranty being voided.



IMPORTANT

If you need to transport the autoloader, the shipping lock and label must be replaced on the top cover to secure the robotics for transportation.

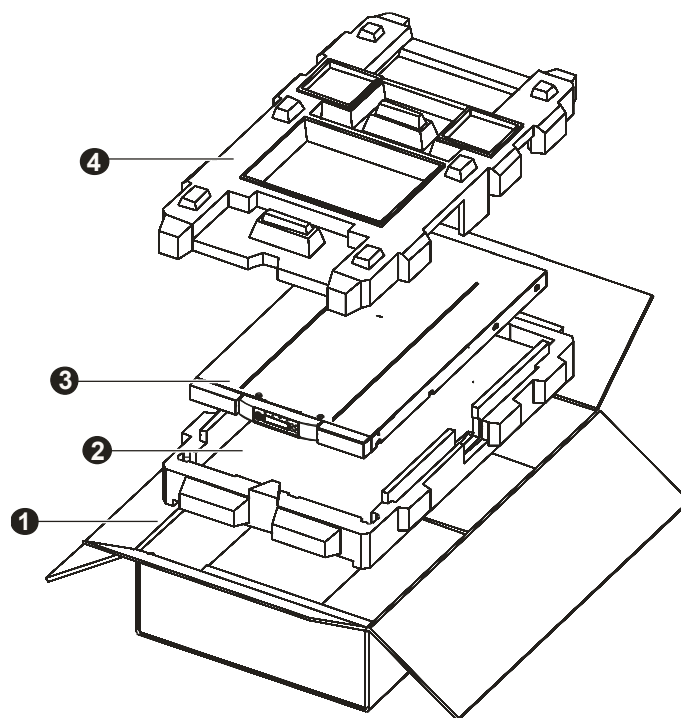

Number	Description
1	Top Packing Shell
2	Rack rails
3	Autoloader
4	Bottom Packing Shell
5	Shipping Carton

Troubleshooting

Installation problems

Problems encountered during the installation of the autoloader are usually caused by improper SAS or Fibre Channel configuration, application software configuration errors, or an incorrectly configured operating system. If the application software that you are using is not communicating with the autoloader after installation, check the following:

- **Compatibility:** Ensure that the autoloader is compatible with the host bus adapter (HBA) and data protection application you plan to use. For a list of compatible adapters and application software, check with your host adapter manufacturer or data protection application vendor.
- **Host Adapter Installation:** Verify that your host adapter is installed correctly. Refer to the manual that came with your host adapter for installation and troubleshooting instructions. Make sure that the host adapter is properly seated in the motherboard slot and the operating system correctly detects the host adapter. Make sure that the proper device driver is installed for the host adapter.
- **Data Protection Application Installation:** Refer to the documentation included with your backup or archive application for instructions on how to verify proper installation. Some software packages require an additional module to communicate with the autoloader robotics.
- **Device Driver Installation:** Make sure that the proper device driver, if applicable, is installed for the autoloader. Many backup applications use their own drivers for the autoloader and drive. Before installing a driver, make sure it will not conflict with the software.

Troubleshooting Table

Power Problems

Problem	Solution
Autoloader does not power on	<ul style="list-style-type: none"> • Check all power cord connections • Make sure the power button on the front panel is in the ON position • Make sure there is power to the outlet. Try another working outlet • Replace the power cord. • Contact Symply Support
No display messages appear (on the OCP)	<ul style="list-style-type: none"> • Make sure the power cord is connected • Make sure the power switch is on. • Power cycle the autoloader • Update the autoloader firmware • Contact Symply Support

Tape Movement Problems

Problem	Solution
Tape stuck in drive	<ul style="list-style-type: none"> • Power cycle the autoloader, allow it to complete initialization, which in rare cases can take as long as 10 minutes, and then retry unloading the tape using the autoloader operator control panel. • Allow the tape drive to complete all operations. This may take as long as ten minutes if you reset or cycle power on the autoloader while the cartridge is positioned at the physical end of the media • Make sure that the backup software is not reserving the slot or preventing the tape drive from ejecting the cartridge. The backup software needs to cancel the reservation and any hold it has on the tape drive. Temporarily disconnecting the autoloader from the host server and power cycling eliminates the host and its software as a problem source. • Contact Symply Support
Tape stuck in storage slot	<ul style="list-style-type: none"> • See "Removing stuck tapes from slots"

Media Problems

Problem	Solution
Cleaning or data cartridge incompatible with drive	<ul style="list-style-type: none"> • Make sure you are using data and cleaning cartridges that are compatible with the drive and model of your autoloader. The autoloader automatically unloads incompatible cartridges, the Media Attention LED flashes, and an exclamation mark (!) is displayed in the inventory display for the indicated slot number. • Export the media in order to clear the state
Cannot write to or read from tape.	<ul style="list-style-type: none"> • Make sure that the cartridge is write enabled (move the write-protect switch to the enabled position). • Make sure you have the appropriate data cartridge for your autoloader model • Make sure you are using an Ultrium cartridge that has not been degaussed. Do not degauss Ultrium cartridges. • Make sure that the cartridge has not been exposed to harsh environmental or electrical conditions and is not physically damaged in any way. • Some backup applications do not read or write to cartridges that were created using a different backup application. In this case, you may have to perform an erase, format, or label operation on the cartridge • Make sure you understand any data protection or overwrite protection schemes that your backup application may be using, which could prevent you from writing to a given cartridge • Retry the operation with a different, known good tape. • Clean the tape drive. See "Cleaning the tape drive" and retry the operation • Contact Symply Support

Cleaning

Problem	Solution
Cannot load the cleaning cartridge	<ul style="list-style-type: none"> • Make sure you are using an Ultrium universal cleaning cartridge. • Make sure the cleaning cartridge has the correct barcode label • Contact Symply Support

OCP Errors (Front Panel)

Problem	Solution
"!" in autoloader operator panel inventory display	<ul style="list-style-type: none"> • See "Operator control panel (OCP) overview" • Contact Symply Support
There is an error code on the LCD	<ul style="list-style-type: none"> • Look up the error code, try to resolve the failure, and power cycle "Tape autoloader error codes" • Contact Symply Support

Poor Performance

Problem	Solution
	<ul style="list-style-type: none"> • Try a new cartridge. A marginal cartridge can cause performance problems due to bad spots on the tape requiring retries. • Backing up data that compresses poorly or is already compressed will lower performance. • Check the size of the files. Small file size can impact performance • Check the network bandwidth from the host computer. If you are backing up data over a network, consider comparing to a local-only backup • Make sure the backup server has enough memory to handle the bandwidth of the backup or restore. • Confirm that the backup application and/or operating system is utilizing correct block sizes for transferring data to the tape drives. Refer to the backup application documentation for details. • Clean the tape drive • Contact Symply Support

Media Attention LED

Problem	Solution
Contamination by loose debris.	<ul style="list-style-type: none"> Avoid contamination by ensuring that the autoloader is installed in a clean, contamination-free environment. Cartridges should be stored vertically in their plastic cases. Continue cleaning the tape drive as needed.
Non-acclimated media	<ul style="list-style-type: none"> A cartridge should be acclimated for at least 24 hours before being used, particularly if it has been stored at a substantially different temperature or level of humidity than the autoloader.
Cartridge is incompatible	<ul style="list-style-type: none"> Use only cartridges that are compatible with the drive type. Make sure you are using an Ultrium universal cleaning cartridge, see "Cleaning the tape drive"
Expired cleaning cartridge	<ul style="list-style-type: none"> A cleaning cartridge will expire after 50 cleans
Bad/defective/contaminated media	<ul style="list-style-type: none"> If the Media Attention LED is cleared and – although the drive has been cleaned - immediately re-displays each time a particular cartridge is reloaded that cartridge should be suspected as being defective. Export the cartridge and load a known good cartridge. In some cases, a cartridge can be worn out, have a defective Cartridge Memory, or have been formatted as a Firmware Upgrade Cartridge Any cartridge that is suspected of being defective or contaminated should NOT be reused in any drive. Any cartridge that has got stuck or jammed in a tape drive should NOT be reused in any drive.
Device not detected on SAS or FC Bus	<ul style="list-style-type: none"> Check cabling Check the host adapter is correctly installed along with correct drivers Check that the host adapter supports LUN scanning and this feature is enabled Check that the host adapter supports TLR Power on device before powering on the host computer Check that the device has been powered on and is not in an error state.

Service Procedures

Removing stuck tapes from slots

If the Operator Control Panel or the Remote Management Unit is still operational:

- 1) Move the tapes from the drive(s) to the magazines using the Move Tape command, or the Forced Drive Eject command. See "Moving tapes in the autoloader."
- 2) Use the magazine removal process to release the magazine and remove it from the autoloader.
- 3) The finger holes on the back side of the magazines allow the user to pull the cartridges out of the slot. Remove and insert the cartridge mechanically. Repeat the process as required.

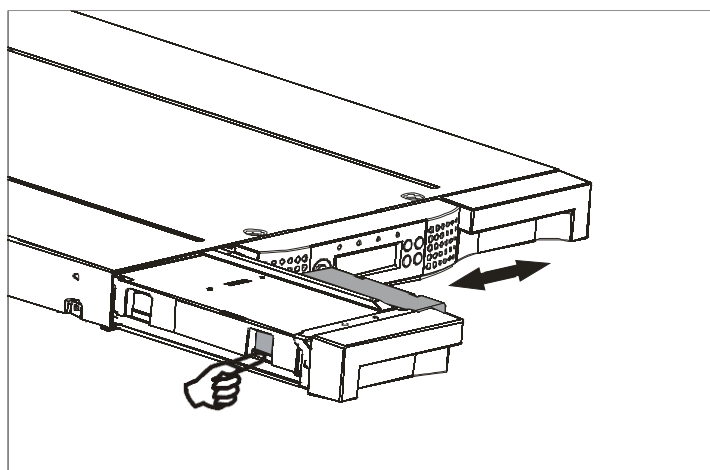

- 4) During this process any burr on the cartridges will be removed.
- 5) Insert cartridge in the magazine.
- 6) Put the magazine back to the tape autoloader.

Removing and replacing a magazine using the OCP

The magazines should be released using the Operator Control Panel (OCP) or the Remote Management Unit (RMU). Recommends that you release the magazine using the OCP or RMU, however, if the OCP process fails, or if the magazine needs to be removed when the power to the tape autoloader is off, you can manually release the magazines.

This OCP option lets you gain access to the left and right magazine. Access to the magazines requires the use of the Administrative password.

To remove a magazine:

- 1) From the Home screen, press Previous or Next on the OCP until the screen displays Operations.
- 2) Press Enter to select.
- 3) Press Previous or Next until the screen displays either Unlock Left Magazine, or Unlock Right Magazine.
- 4) Press Enter to select the desired magazine to unlock.
- 5) Enter the Administrative password if requested.
- 6) The display will read Left Magazine Unlocked, or Right Magazine Unlocked.
- 7) Pull the released magazine out of the autoloader.
- 8) The screen will now display Insert Left Magazine, or Insert Right Magazine. The autoloader cannot perform any other operation until the magazine is replaced. After exchanging tapes in a magazine, slide the magazine completely into the autoloader. The magazine will lock into place once it is correctly installed and the autoloader will inventory the magazine.



IMPORTANT

The magazine must only be removed manually in an emergency. Failure to follow normal procedure can cause data loss and equipment damage.

Removing a magazine using Remote Management Interface

To login, enter the correct password, and press Enter.

Go to Operations > Magazines

This page allows the user to release the right or left magazine from the autoloader.

Operations: Magazines page.

Magazine emergency release

If you are not able to remove the magazines using OCP and RMU, an emergency release mechanism is available.

To remove a magazine:

- 1) Unplug the power cord from the autoloader.
- 2) Find the access holes for the right and left magazines.

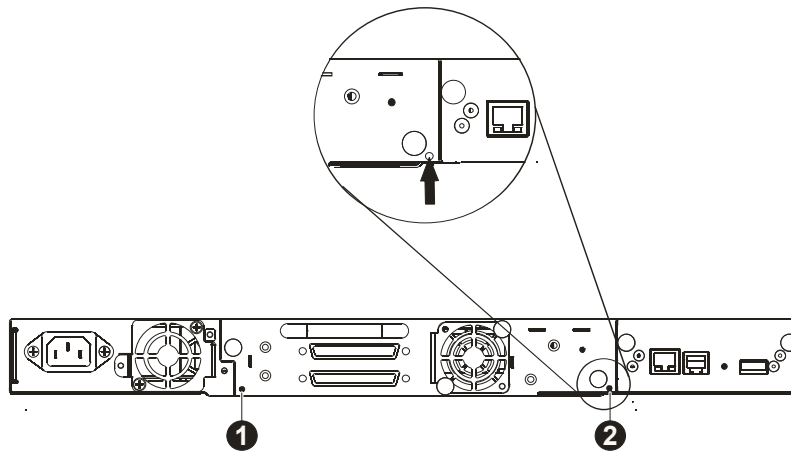

Number	Description
1	Right magazine release
2	Left magazine release

- 3) To manually release the magazines, push the end of a straightened paper clip into the access hole for each magazine at the back of the autoloader. While holding the paper clip, have a second person pull the magazine out of the front of the unit.

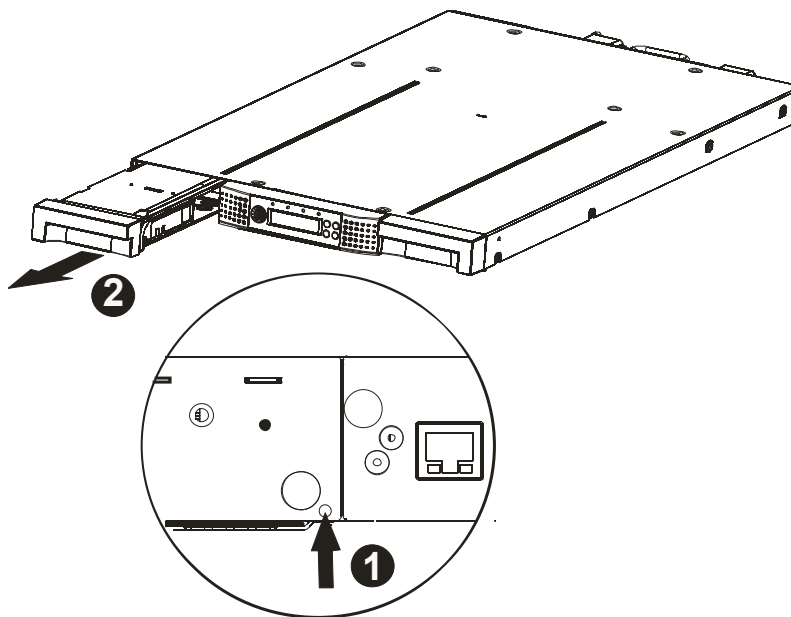

Number	Description
1	Insert pin into access hole
2	Release and remove magazine

If there are additional tapes still in the autoloader, or if you were unable to manually remove the magazines and drive, please contact the Symply support team for further information.

Tape autoloader error codes

If an error occurs during operation of the autoloader, the autoloader stops the current operation and displays an error code on the LCD screen. Unless otherwise noted in the Table on page XXX, try to resolve the error by cycling power to the autoloader and retrying the last operation. If the error persists, contact support personnel Support menu tree.

Example error code:

EVENT -6

A5 F1

Where:

- Sequence number -6 indicates the position in sequence list, 0 being the most recent.
- Log shows a load error (code A5 = fan error, sub code F1 = caused by the fan at the back connector plate).

The event log with the autoloader also includes a date stamp for each event. Press Enter to display the associated timestamp in the following format:

ddd:hh:mm:ss:HH

where:

ddd: days

hh: hours

mm: minutes

ss: seconds

HH: 1/100 second

A description of each error code and possible solution is provided in the following tables:

Error Code	Description	User Action
80	Barcode Reader Error, cannot initialize BCR	Retry operation; after several occurrences contact technical support
81	Barcode Reader Error, no response from BCR	Retry operation; after several occurrences contact technical support
82	EEPROM Error, no response from EEPROM (located on robotic controller)	Retry operation; after several occurrences contact technical support
83	Robotic controller generic problem	Reset the unit and retry operation. After several occurrences contact technical support
84	Setting of gripper motor parameters failed	Reset the unit and retry operation. After several occurrences contact technical support
85	Setting of slider motor parameters failed	Reset the unit and retry operation. After several occurrences contact technical support
86	Setting of elevator motor parameters failed	Reset the unit and retry operation. After several occurrences contact technical support
87	Setting of rotation motor parameters failed	Reset the unit and retry operation. After several occurrences contact technical support
88	Setting of sled motor parameters failed	Reset the unit and retry operation. After several occurrences contact technical support

Error Code	Description	User Action
89	Gripper blocked	Run 'Autoloader Health Check', after several occurrences contact technical support
8A	Slider blocked	Run 'Autoloader Health Check', after several occurrences contact technical support
8B	Elevator blocked	Run 'Autoloader Health Check', after several occurrences contact technical support
8C	Rotation blocked	Run 'Autoloader Health Check', after several occurrences contact technical support
8D	Sled blocked	Run 'Autoloader Health Check', after several occurrences contact technical support
8E	Cannot find gripper block within the expected range	Run 'Autoloader Health Check', after several occurrences contact technical support
8F	Cannot find slider block within the expected range	Run 'Autoloader Health Check', after several occurrences contact technical support
90	Cannot find elevator block within the expected range	Run 'Autoloader Health Check', after several occurrences contact technical support
91	Cannot find rotation block within the expected range	Run 'Autoloader Health Check', after several occurrences contact technical support
92	Cannot find sled block within the expected range	Run 'Autoloader Health Check', after several occurrences contact technical support

Error Code	Description	User Action
93	Gripper outside range, Gripper has reached a position beyond the expected range	Run 'Autoloader Health Check', after several occurrences contact technical support
94	Slider outside range, Slider has reached a position beyond the expected range	Run 'Autoloader Health Check', after several occurrences contact technical support
95	Elevator outside range, Elevator has reached a position beyond the expected range	Run 'Autoloader Health Check', after several occurrences contact technical support
96	Rotation outside range, Rotation has reached a position beyond the expected range	Run 'Autoloader Health Check', after several occurrences contact technical support
97	Sled outside range, Sled has reached a position beyond the expected range	Run 'Autoloader Health Check', after several occurrences contact technical support
98	Cartridge present sensor not found	Run 'Autoloader Health Check', after several occurrences contact technical support
99	Sled home sensor not found	Run 'Autoloader Health Check', after several occurrences contact technical support
9A	Rotation home sensor not found	Run 'Autoloader Health Check', after several occurrences contact technical support
9B	Sled position sensor (prism sensor) not found,	Run 'Autoloader Health Check', after several occurrences contact technical support
9C	Gripper range out of specification	Run 'Autoloader Health Check', after several occurrences contact technical support

Error Code	Description	User Action
9D	Slider range out of specification	Run 'Autoloader Health Check', after several occurrences contact technical support
9E	Elevator range out of specification	Run 'Autoloader Health Check', after several occurrences contact technical support
9F	Rotation range out of specification	Run 'Autoloader Health Check', after several occurrences contact technical support
A0	Sled range out of specification	Run 'Autoloader Health Check', after several occurrences contact technical support
A1	Open Mail Slot (Import/Export Element) failed	Retry operation, after several occurrences contact technical support
B0	Robotic controller response timeout. A command did not complete in the required amount of time.	Reset the unit and retry operation. After several occurrences contact technical support
B1	NACK received from robotic controller	Reset the unit and retry operation. After several occurrences contact technical support
B2	Robotic controller communication failed	Reset the unit and retry operation. After several occurrences contact technical support
B3	Robotic controller urgent stop due to a released magazine	Check if magazine are completely inserted and retry operation. After several occurrences contact technical support
B4	Cartridge did not transport completely Gripper could not pick cartridge and CP sensor not present After pushing the cart CP sensor still present	

Error Code	Description	User Action
B5	Robotic controller doesn't respond on command	Reset the unit and retry operation. After several occurrences contact technical support
C0	Network initialization failed	Check network cable and network configuration. If the error recurs, contact technical support
C1	Telnet Interface initialization failed	Check network cable and network configuration. If the error recurs, contact technical support
C2	Webserver initialization failed	Check network cable and network configuration. If the error recurs, contact technical support
C6	Ping command did not reached target	Check network cable and network configuration. If the error recurs, contact technical support
C7	Cannot Upgrade from USB	Retry of Firmware upgrade, if not successful contact technical support
D0	ROM error. ROM checksum incorrect	Retry of Firmware upgrade, if not successful contact technical support
D1	RAM error. Power on Self Test (POST) has failed,	Retry operation; after several occurrences contact technical support
D2	NVRAM error. R/W operation to NVRAM has failed	Retry operation; after several occurrences contact technical support
D3	CTC Error. Timer unit has failed during POST.	Retry operation; after several occurrences contact technical support

Error Code	Description	User Action
D4	UART Error. Frame overrun or Parity Error on serial Interface.	Retry operation; after several occurrences contact technical support
D5	Display Error Communication to display failed	Retry operation; after several occurrences contact technical support
D6	Memory Error, Stack and heap overflow.	Retry operation; after several occurrences contact technical support
D7	Fatal system error	Retry operation; after several occurrences contact technical support
D8	Data base error	Retry operation; after several occurrences contact technical support
D9	No SCSI IC detected	Retry operation; after several occurrences contact technical support
DA	In Autoloader Verify Test the barcode reader has read different barcode data for the same cartridge label	Check barcode label on scratch cartridge and run Autoloader Verify Test again. If the error recurs, contact technical support
DB	Warning event! See section below	
DC	I ² C Bus Failure	Retry operation; after several occurrences contact technical support
DD	Warning event! See section below	
DE	Warning event! See section below	
DF	Warning event! See section below	

Error Code	Description	User Action
E0	Incompatible magazine detected	Check type of lowest left magazine
F0	Drive Overtemperature Condition The subcode indicates which drive is affected <u>Example:</u> Subcode 01: drive #1	Check ambient temperature conditions and check all fans, after several occurrences contact technical support
F1	Drive Communication Error, Autoloader controller has lost communication to drive The subcode indicates which drive is affected <u>Example:</u> Subcode 01: drive #1	Retry operation; if not successful contact technical support
F2	Drive Sled not present The subcode indicates which drive sled is affected <u>Example:</u> Subcode 01: drive sled #1	Retry operation; if not successful contact technical support
F3	Drive Hardware Error The subcode indicates which drive is affected <u>Example:</u> Subcode 01: drive #1	Cycle Power, after several occurrences contact technical support
F4	Drive Load Timeout Drive has run in a timeout while loading a tape The subcode indicates which drive is affected	Retry operation; if not successful contact technical support

Error Code	Description	User Action
F5	<p>Drive Unload Timeout Drive has run in a timeout while unloading a tape</p> <p>The subcode indicates which drive is affected</p>	<p>Retry operation; if not successful contact technical support</p>

Warranty Information

The SymplyPRO XTL system comes with a limited three (3) year warranty, but with the option to purchase an upgrade to a five (5) year warranty.

Warranty and technical support service can be accessed at www.support.gosymply.com

SYMPLY (“the Company”) warrants its products will be free from defects in material and workmanship for three years from the date of purchase of the product.

This Limited Warranty only applies to the original purchaser of the product and is not transferable to subsequent owners.

This Limited Warranty is void if the product is subjected to abuse, misuse, abnormal, excessive or improper conditions (including, without limitation, attempts to utilize the product under any condition that exceeds its design capabilities, or any other use beyond the use specified in any product instructions), or if the product is altered or modified in any manner. This Limited Warranty does not cover damage to the product due to external causes (including, without limitation, accident, liquids, chemicals, oxidation, corrosion, or exposure to the elements), or problems caused by use of parts and components not supplied by the Company.

The sole remedy under this Limited Warranty is product repair, replacement, or refund of the purchase price, at the sole discretion of the Company. In order to make a claim the purchaser must ship the product to the Company at the purchaser’s expense, together with proof of purchase and a description of the nature of the defect. The Company will not be held responsible for any product that is damaged or lost in transit to the Company.

PURCHASER AGREES THAT SYMPLY SHALL NOT BE LIABLE FOR ANY SPECIAL, INCIDENTAL, INDIRECT, SECONDARY OR CONSEQUENTIAL DAMAGES, OR FOR THE DAMAGE, INJURY, OR LOSS OF LIFE, PROPERTY OR OTHER PRODUCTS THE PURCHASER CONNECTS TO THE PRODUCT, OR LOSS OF REVENUE OR DATA, WHETHER BASED ON CONTRACT, TORT, PRODUCTS LIABILITY OR ANY OTHER LEGAL THEORY, EVEN IF THE DAMAGE, INJURY OR LOSS IS CAUSED BY THE NEGLIGENCE OR OTHER FAULT OF SYMPLY. THE FOREGOING WARRANTY IS THE ONLY WARRANTY MADE BY SYMPLY, AND SYMPLY MAKES NO OTHER WARRANTIES, INCLUDING, BUT NOT LIMITED TO, ANY IMPLIED WARRANTY OF MERCHANTABILITY OR FITNESS FOR A PARTICULAR PURPOSE.

This Limited Warranty shall be governed by the laws of England and the parties hereby submit to the exclusive jurisdiction of the English courts for that purpose. If any provision is declared void or unenforceable by a court of competent jurisdiction with respect to particular circumstances, such provision shall remain in full force and effect in all other circumstances. If any provision is declared entirely void or unenforceable by a court of competent jurisdiction all other provisions of these Terms and Conditions shall remain in full force and effect.